

– weishaupt –

product

Information on compact burners



Digital dual-fuel burners

Weishaupt dual-fuel burners, WGL30 and WGL40 (70–550 kW)

A burning passion for quality



Ultra-modern research and production methods, rigorous quality control, and a comprehensive service network ensure the quality for which Weishaupt is renowned

Technological progress is our motivation. It has been driving us for more than 65 years to keep setting new standards for the combustion equipment industry.

Our own Research and Development Centre is constantly working both on the development of new products and on the optimisation of existing ones.

We consider it is not only our goal but our responsibility to go above and beyond current legislative requirements to develop combustion systems which emit ever fewer pollutants, save ever more energy, and combine ecology and economy in a practical manner.

Therefore, not only do we invest in research and technology, but we also only ever work with the best materials, using the latest tools, and we carry out meticulous quality control checks.

Millions of times over, Weishaupt burners have proven to heating specialists and end users alike that they are extremely reliable, durable, environmentally friendly, and technologically advanced; a fact also borne out by our numerous prizes for design and innovation.

Burners with outputs ranging from 12.5 to 32000 kW are manufactured at our ultra-modern facilities in Germany and every single one undergoes a mechanical and electrical function test there. It is this combination of technology and effective quality control that helps to safeguard Weishaupt's renowned reputation for quality.

A new burner is always an investment in the future. Costs always need to be well-balanced against use but, ultimately, long-term overall success depends on quality, technology, and safety. Deciding on a Weishaupt burner is always a safe investment in the future.

Contents

	Page
A hallmark of practical combustion technology	5
WGL30/40 dual-fuel burners with optional O ₂ trim	6
Digital combustion management: reliable and easy to use	8
Optional W-FM25 expansion modules	9
Overview of burner control, model designation	10
Use	11
WGL30 – Burner selection/gas valve train sizing	12
WGL40 – Burner selection/gas valve train sizing	13
Order Nos, extra equipment	14
Technical data, dimensions	15

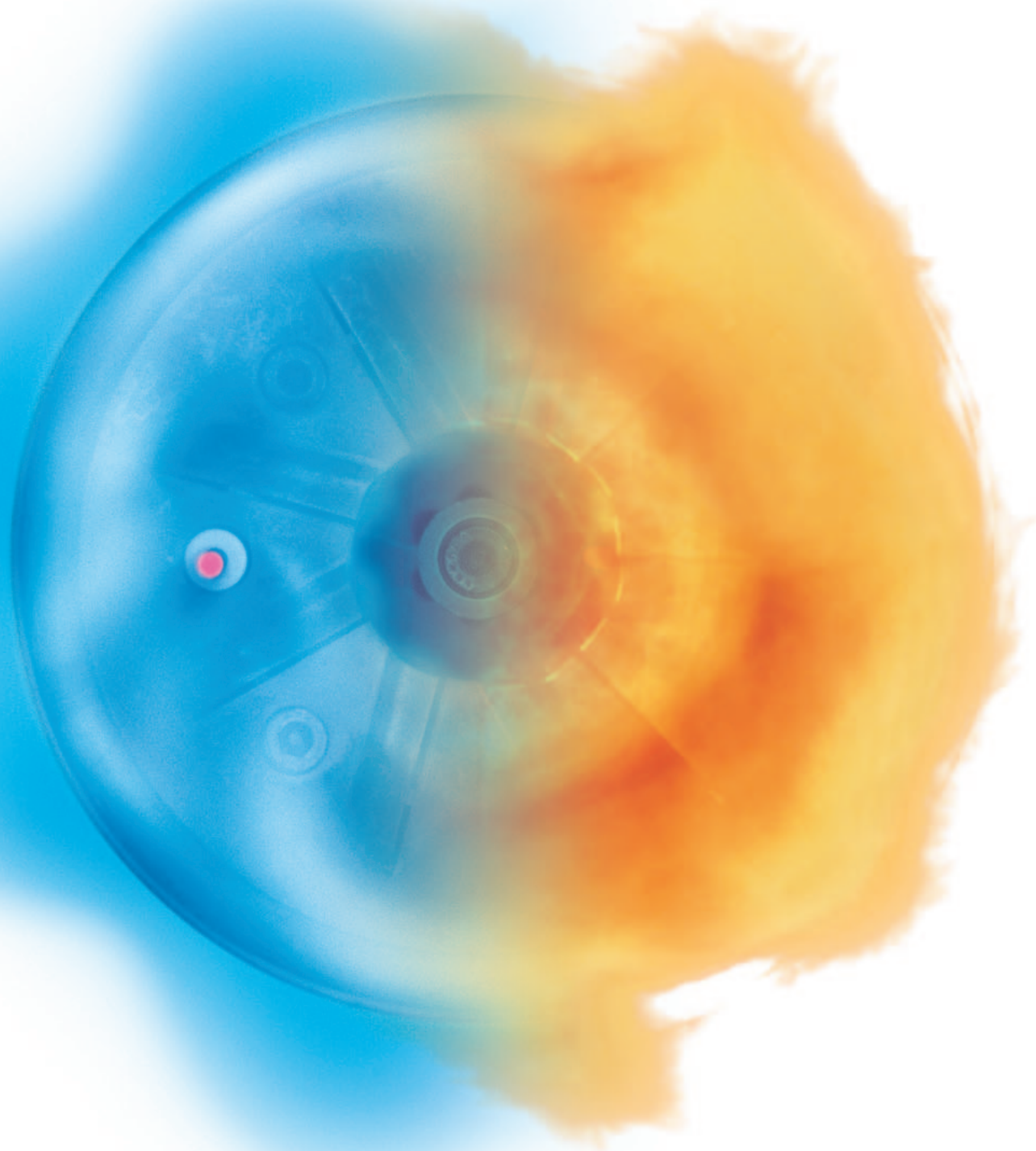

A hallmark of practical combustion technology

A safe investment in the future

Reliable and economical: The million-fold success of Weishaupt's compact burners is the result of an unrelenting orientation towards quality and customer satisfaction. The equipment has been continually developed and improved over decades.

The latest production methods and very stringent quality checks of all products ensure Weishaupt's reputation for quality. In choosing Weishaupt you are making a safe investment in the future.

The WGL slots seamlessly into the range of W-series burners, bringing all the advantages of that product family together with additional fuel flexibility.

Large capacity range

The burners' capacity ranges of 70 to 340 kW and 125 to 550 kW make them both suitable for a wide range of heat generators.

Digital combustion management for reliability and ease of use

Weishaupt is a pioneer in this field. Digital combustion management offers greater ease of use, simple servicing, even greater reliability in operation, and, last but not least, an extremely attractive price to capacity ratio. Furthermore, this intelligent technology enables the burner to be integrated with complex building management systems.

Electronic ignition

The ignition unit used on all Weishaupt W-series burners is very energy efficient and extremely reliable.

Flame monitoring

Flame monitoring systems are responsible for the high operational readiness and maximal safety of the burner.

Weishaupt WGL burners use an infrared flicker detector that can monitor both gas and oil flames.

Gas multifunction assembly

The burner's gas multifunction assembly incorporates the following components and functions:

- Servo-controlled governor to ensure a continual gas pressure
- 2 Class-A solenoid valves
- Filter
- Gas pressure switch

If the gas pressure falls too low, a low gas pressure program is started. The gas pressure switch also provides automatic valve proving.

Valve proving as standard with the W-FM25 combustion manager

The low gas pressure switch is used to check the tightness of the gas valves, thereby providing valve proving without the need for any additional components or costs.

O₂ trim

The various options available with the W-FM25 series of combustion managers bring the latest technology to the compact burner segment. Innovative technology enables efficiency-optimising measures such as O₂ trim to be produced more cost effectively. With these technologies it is possible for investments in burners to be quickly amortised.

Diagnosis via laptop

A laptop computer can be connected to the combustion manager, offering easy combustion optimisation and fault analysis. A package of interrogation software and connection cables is available for this.

Outstanding service

Weishaupt has an extensive worldwide sales and service network. Customer service is available around the clock. Weishaupt's optimal in-house training ensures service technicians are of the highest calibre.

The key points:

- Fully electronic control and diagnosis
- Sliding-two-stage or modulating load control when firing on gas, two-stage load control when firing on oil
- The separately motorised oil pump is decoupled while the burner is firing on gas
- Microprocessor-controlled combustion manager
- Burner set via control unit with LCD screen
- Integrated gas valve proving
- Optional O₂ trim
- Optional expansion module to provide a Modbus/Profibus interface
- Error message display
- Hours run meter with burner start counter
- Electronic gas/air compound with separate stepping motor actuators
- The diffuser can be adjusted during setup
- Fuel selection switch

WGL30 / 40 dual-fuel burners with optional O₂ trim

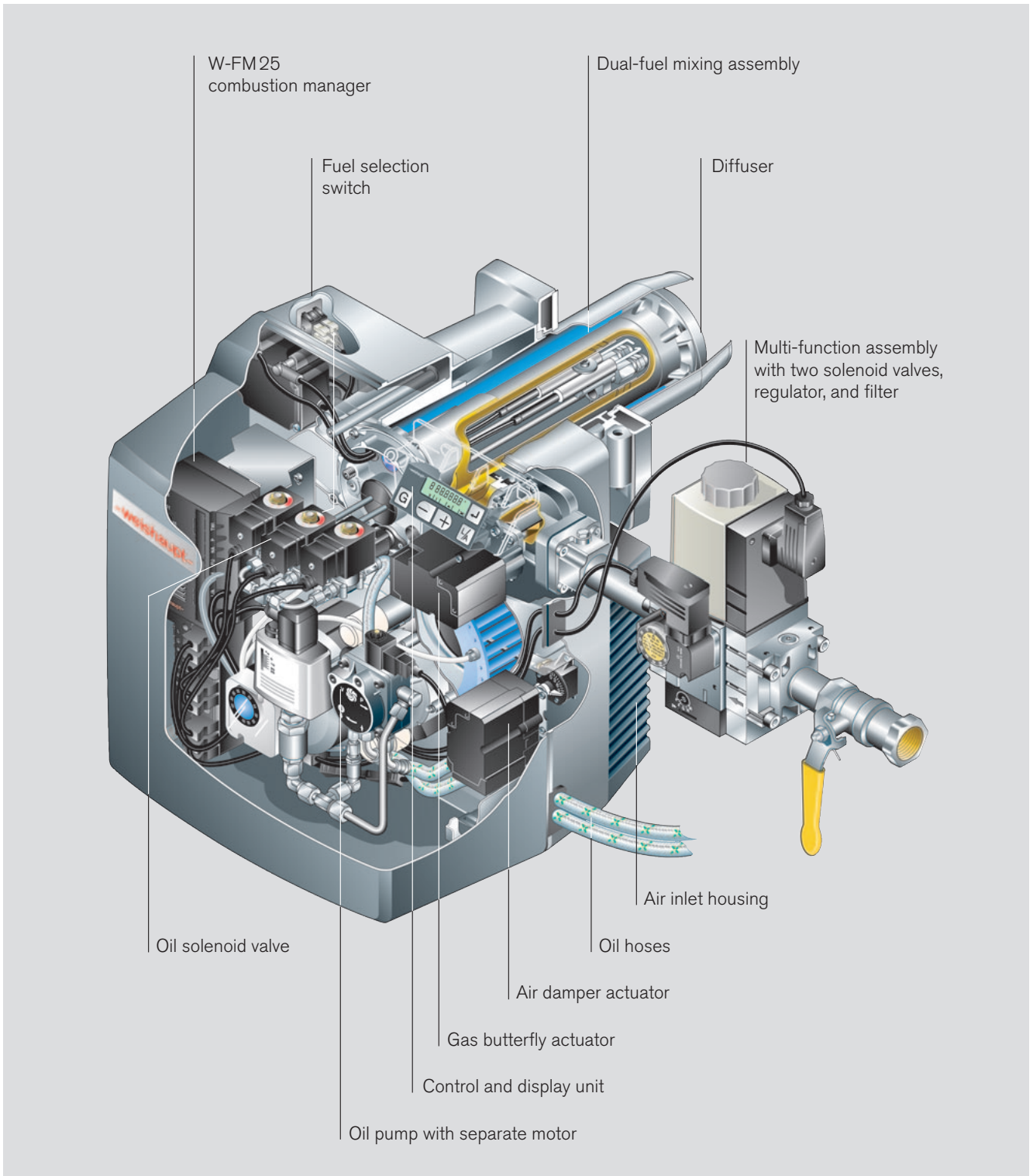

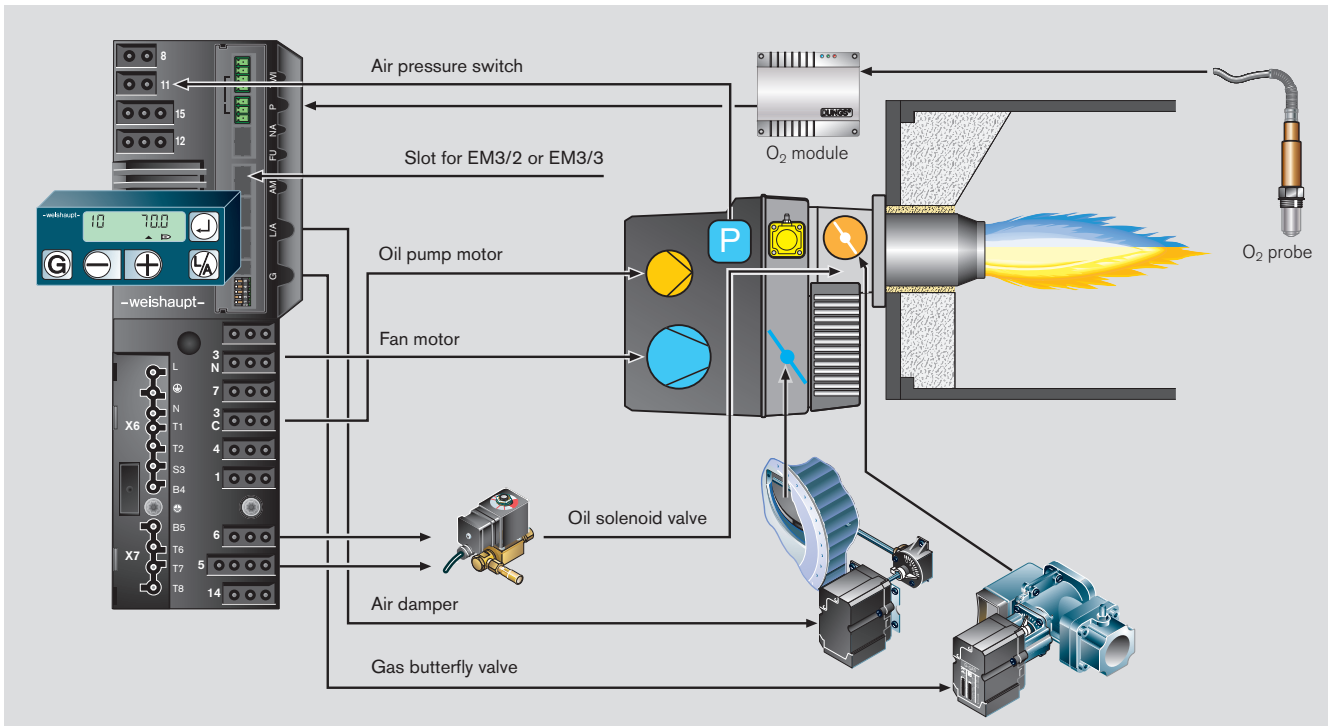

Conceptual drawing of WGL30/40 with O₂ trim

The key points:

- Sliding-two-stage or modulating load control when firing on gas, two-stage load control when firing on oil
- W-FM25 O₂ for O₂ trim
- The separately motorised oil pump is decoupled while the burner is firing on gas
- Fuel changeover via selection switch or field bus module
- Non-interchangeable plugs ensure the correct electrical connection of all components
- Safety is ensured by the reciprocal monitoring of two microprocessors
- Fully electronic control and diagnosis
- Flame monitoring via KLC/FLW infrared flicker detector
- Electrical remote reset is possible
- Optional expansion modules with either a Modbus interface or analogue and digital inputs and outputs
- The separate PC connection offers,

through the use of the Vision Box software, additional options such as:

- Setting of the pre-purge time
- Display of the operational sequence and the adjustment of functional parameters
- Simplified, display led commissioning
- LCD screen with interrogation, service, and parameterisation functions. The burner can be set directly via the operating keys
- Available with Canadian and US type approvals and 120 V / 60 Hz electrics

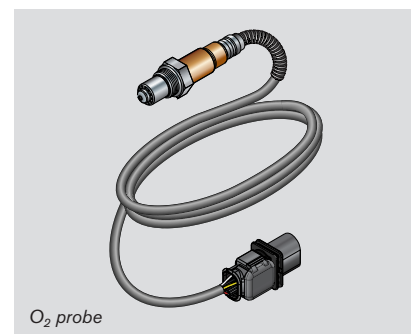

O₂ probe



O₂ module

Digital combustion management: reliable and easy to use

Combustion manager	W-FM 25
Fuels	
Gaseous	●
Liquid (distillate)	●
Gaseous / liquid (distillate)	●
Features	
Intermittent firing	●
Integrated gas valve proving	●
Number of actuators	2
Actuators with stepping motor	2
Number of compound settings	2
Flame monitoring	KLC/FLW
Fuel metering via input pulse	●
Service software	Vision Box
Efficiency optimisation	
O ₂ trim	○ ¹⁾
Control	
Stage switching inputs (thermostat/ pressure control)	●
Three-term switching input	●
0 / 4–20 mA or 0/2–10 V analogue input/output	○ ²⁾
Bus systems	
Modbus RTU	○ ³⁾
Profibus	○ ³⁾
Controls positioning	
Burner-mounted combustion manager	●
Removable control unit	10 m
Electrical supply	
120 V, 50 Hz / 60 Hz	●
230 V, 50 Hz / 60 Hz	●
Approvals	
Europe CE (230 V / 50 Hz)	●
Australia AGA (240 V / 50 Hz)	●
USA/ Canada CSA (120 V / 60 Hz)	●
● Standard ○ Optional	
¹⁾ PO O ₂ version	
²⁾ With EM3/3 expansion module	
³⁾ With EM3/2 expansion module	

Digital combustion management for reliability and ease of use

Weishaupt is a pioneer in this field. Digital combustion management offers greater ease of use, simple servicing, even greater reliability in operation, and, last but not least, an extremely attractive price to capacity ratio. Furthermore, this intelligent technology enables the burner to be integrated with complex building management systems.

All of Weishaupt's W-series burners are fitted as standard with a digital combustion manager. The unit's microprocessors control and monitor all burner functions. As a result, Weishaupt burners are easy to use, precise, and reliable.

The digital combustion manager also offers the possibility of communicating with other systems via an integrated bus connection. This allows a technician to monitor the operation of the burner and remotely diagnose any errors.

The key points:

- Non-interchangeable plugs ensure the correct electrical connection of all components
- Safety is ensured by the reciprocal monitoring of two microprocessors
- Simplified, display led commissioning
- LCD screen with interrogation, service, and parameterisation functions. The burner can be set directly via the operating keys
- Flame monitoring via KLC/FLW infrared flicker detector
- Electrical remote reset is possible
- The optional bus connection offers functions such as:
 - Interfacing with building management systems
 - Remote monitoring and diagnosis via self-dialling modem
- The separate PC connection offers, through the use of the Vision Box software, additional options such as:
 - Setting of the pre-purge time
 - Display of the operational sequence and the adjustment of functional parameters

Optional W-FM 25 expansion modules

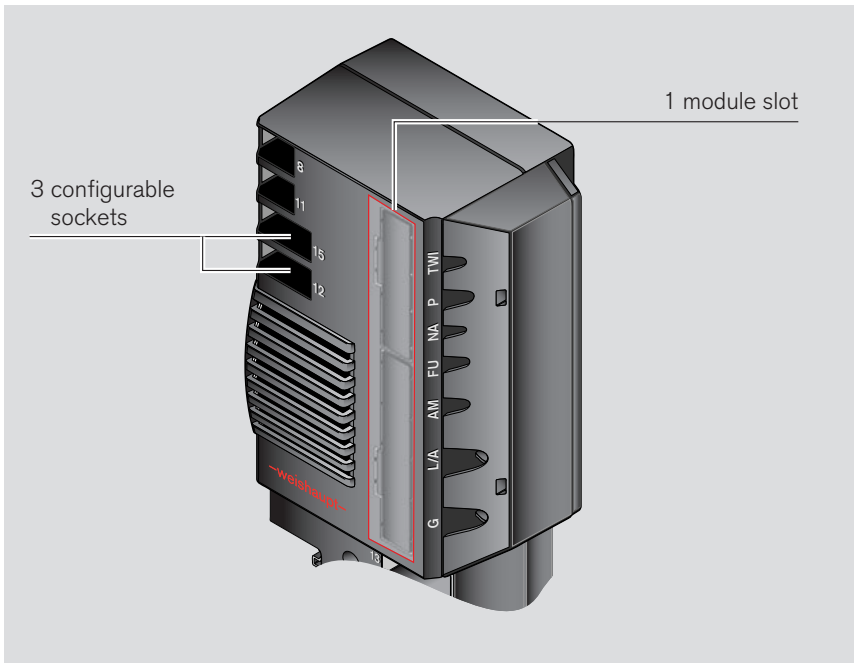

W-FM 25 combustion manager

- Configurable inputs (summary)

Socket 12

- VPS valve proving
- Proof of valve closure (POC)

Socket 14

- Remote reset
- Start release
- Contact-dependent post-purge

Socket 15

- High gas pressure switch
- Extraneous air pressure switch

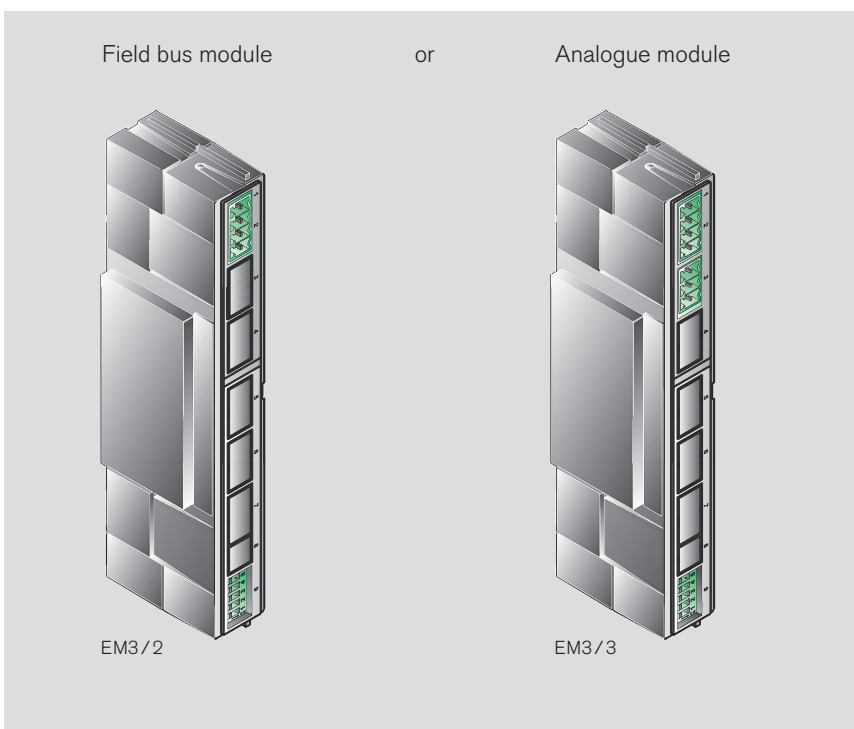

Field bus module – Modbus / Profibus

By way of example, the following data can be read or changed:

- Burner ON / OFF
- Fuel changeover
- Current degree of modulation
- Required degree of modulation
- Heat demand present
- Flame signal
- Hardware inputs and outputs
- Operating phase
- Hours run
- Fan speed with VSD
- Actuator positions
- Fuel throughputs
- Etc.

Analogue module – input/output

Input: Required burner load

0–20 mA / 4–20 mA

0–10 V / 2–10 V

Output: Current burner load

0–20 mA / 4–20 mA

0–10 V / 2–10 V

Overview of burner control

Model designation

Gas and oil-fired operation

Two-stage (Z)

- Two-term switching (e.g. temperature or pressure stat) causes actuators to drive the burner to partial load or full load in response to heat demand. Single-stage control with low-impact start can also be effected.

Two-stage (oil)

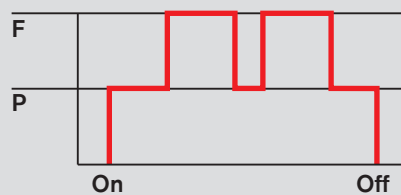

Switching ¹⁾

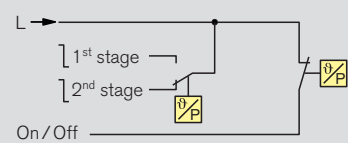

Sliding-two-stage (ZM)

- Two-term switching (e.g. temperature or pressure stat) causes actuators to drive the burner to partial load or full load in response to heat demand. The combustion values between load points are CO and smoke free.

Sliding-two-stage (gas)

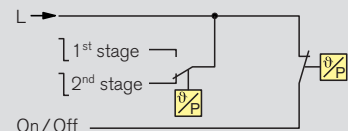
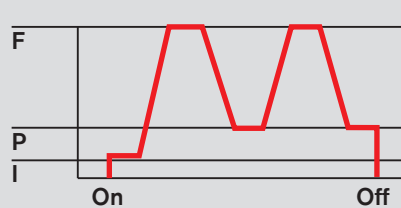

Modulating (ZM)

- An electronic load controller causes actuators to make infinitely variable load adjustments in response to heat demand.
- Available modulation control options for the W-FM25 combustion manager:
 - Three-term switching for an optional external load controller
 - Optional EM3/3 expansion module for an external load controller with an analogue output signal
 - Optional EM3/2 expansion module for a Modbus connection

Modulating (gas)

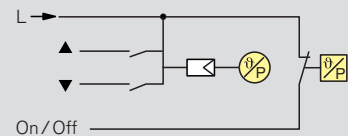
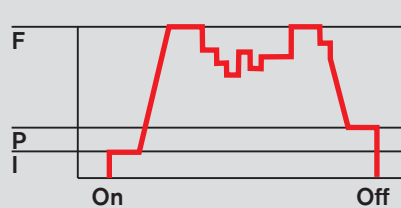

F = Full load (nominal load)
 P = Partial load (minimum load)
 I = Ignition load

¹⁾ Modulating gas control with staged oil control requires an electronic PID controller. In this case, an appropriate temperature sensor or pressure transducer will be required.

Model designation

WGL30/1-C ZM

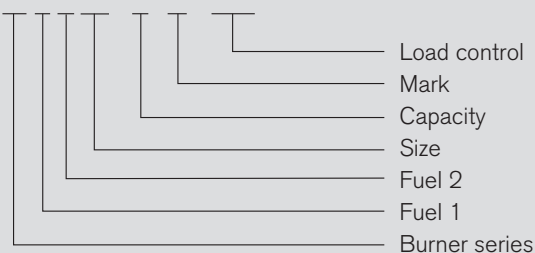

Details	Code-	Meaning	Associated fuel
Series	W	Weishaupt compact burner	
Fuel	G L	Gas Class D/ A2 oil	
Load control	Z ZM	Two-stage Sliding-2-stage/ modulating	Oil Gas

Use

Fuels

Natural gas

LPG

Class D gas oil per BS 2869 / IS 251

Class A2 gas oil per BS 2869 / IS 251

10 % biodiesel blends (B10)

The suitability of fuels of differing quality must be confirmed in advance with Weishaupt.

Applications

Weishaupt WGL30 and WGL40 burners with W-FM25 combustion manager are suitable for intermittent firing on:

- EN 303-compliant heat generators
- LTHW boilers
- Air heaters
- Group II and III steam boilers
- Certain process applications

Permissible ambient conditions

- Ambient temperature
 - 15 to + 40 °C for gas firing
 - 10 to + 40 °C for oil firing
- Maximum 80 % relative humidity, no condensation
- The combustion air must be free of aggressive substances (halogens, chlorides, fluorides etc.) and impurities (dust, debris, vapours, etc.)
- Adequate ventilation is required for operation in enclosed spaces
- For plant in unheated areas, certain further measures may be required

Use of the burner for other applications or in ambient conditions not detailed above is not permitted without the prior written agreement of Max Weishaupt GmbH. Burner service intervals will be reduced to accord with the more extreme operational conditions.

Protection Class

IP 40

Gas supply

EN 88-compliant regulators with safety diaphragms are used for low-pressure supplies.

For high-pressure supplies, an EN 334-compliant high-pressure regulator

should be selected from the following technical booklets:

- Regulators up to 4 bar, Print No. 83001202
- Regulators with safety devices, Print No. 83197902

Maximum Operating Pressure (MOP)

The supplier must safeguard the gas flow pressure such that it cannot exceed the MOP of the burner's gas valve train.

Gas valve train design

Low-pressure valve trains are normally used for gas flow pressures up to a maximum of 300 mbar and a maximum operating pressure (MOP) of 500 mbar. This allows for pressure losses between the transfer station and the valve train. Furthermore, it is assumed that the transfer station utilises components (SSV, regulator) that are not of the highest class of accuracy. In individual cases, following consideration and approval by Weishaupt's headquarters, a gas flow pressure of up to 360 mbar can be approved if the appropriate conditions exist.

High-pressure valve trains are normally used for gas flow pressures greater than 300 mbar.

Standards compliance

The burners are tested by an independent body and fulfil the applicable requirements of the following European Union directives and applied standards:

- EMC** EMC Directive 2014/30/EU
Applied standards
 - EN 61000-6-1 : 2007
 - EN 61000-6-3 : 2007
- LVD** Low-Voltage Directive 2014/35/EU
Applied standards
 - EN 60335-1 : 2010
 - EN 60335-2-102 : 2010
- MD** Machinery Directive 2006/42/EC
Applied standards
 - EN 676 Annex J
- GAR** Gas Appliances Regulation 2016/426/EU
Applied standards
 - EN 676 : 2008
- PED¹⁾** Pressure Equipment Directive 2014/68/EU
Applied standards
 - EN 676 Annex K
 - EN 267 Annex K
 - Conformity assessment procedure: Module B

¹⁾ With the selection of appropriate equipment.

The burners are labelled with

- CE Mark
- CE-PIN per 2009/142/EC
- Identification No. of the notified body

Burner selection / gas valve train sizing

WGL30

WGL30 capacity graph

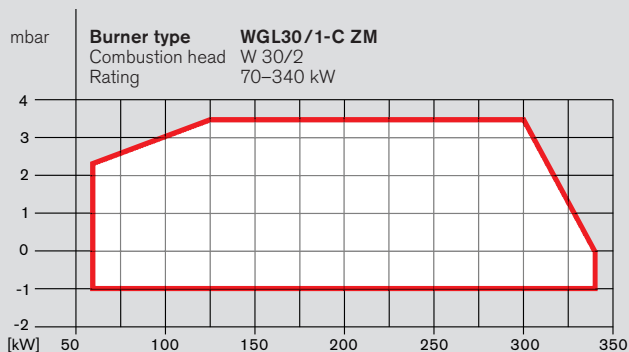

The capacities as a function of combustion chamber pressure are maximum values measured in accordance with EN 676 and EN 267 on idealised flame tubes.

The burner capacity graphs are certified in accordance with EN 676 and EN 267. The stated ratings are based on an air temperature of 20 °C and an installation at sea level. For installations at higher altitudes, a reduction in capacity of 1 % per 100 m above sea level should be taken into account.

The combustion chamber pressure of the heat generator must be added to the flow pressure determined from the chart when sizing the gas valve train. Minimum flow pressure 15 mbar.

Minimum 125 kW full-load firing rate for two-stage operation

WGL30

Burner rating Low-pressure supply (flow pressure in mbar into shutoff valve, $p_{i, max} = 300$ mbar)

[kW]	W-MF 507		W-MF 512	
	Nom. diameter of gas ball valve			
	¾"	1"	1"	1½"

Nat. gas E, LHV = 10.35 kWh/m³ (37.26 MJ/m³), d = 0.606, W_i = 13.295 kWh/m³

125	16	15	15	14
145	16	15	15	14
165	17	16	15	14
185	18	16	15	14
200	18	17	15	15
220	19	18	16	15
240	21	19	16	15
260	22	20	17	15
280	24	21	18	15
300	26	22	19	16
320	28	24	20	17
340	30	26	21	18

Nat. gas LL, LHV = 8.83 kWh/m³ (31.79 MJ/m³), d = 0.641, W_i = 11.029 kWh/m³

125	18	17	17	16
145	19	18	17	16
165	20	18	18	17
185	21	19	18	17
200	22	20	19	17
220	24	21	19	17
240	26	23	20	17
260	28	24	21	17
280	31	26	22	18
300	33	28	24	18
320	36	31	25	20
340	40	33	27	21

LPG*, LHV = 25.89 kWh/m³ (93.20 MJ/m³), d = 1.555, W_i = 20.762 kWh/m³

125	11	11	11	11
145	12	12	11	11
165	12	12	12	11
185	13	13	12	12
200	13	13	12	12
220	14	13	13	12
240	15	14	13	13
260	16	14	13	13
280	16	15	14	13
300	17	16	14	14
320	18	16	15	14
340	19	17	15	14

The LHV is referenced to 0 °C and 1013 mbar atmospheric.

All pressures are in mbar.

* The LPG charts are based on propane, but may also be used for butane.

Please note that an FRS regulator is required at additional cost for gas connection pressures > 150 mbar.

Note:

Shaded areas of the valve train table do not meet TRGI ball valve sizing requirements. For TRGI compliance use the non-shaded area and note additional price of larger ball valve.

Burner selection / gas valve train sizing WGL40

WGL40 capacity graph

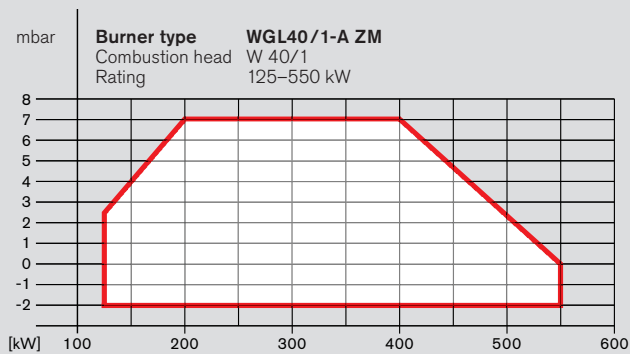

The capacities as a function of combustion chamber pressure are maximum values measured in accordance with EN 676 and EN 267 on idealised flame tubes.

The burner capacity graphs are certified in accordance with EN 676 and EN 267. The stated ratings are based on an air temperature of 20 °C and an installation at sea level. For installations at higher altitudes, a reduction in capacity of 1 % per 100 m above sea level should be taken into account.

The combustion chamber pressure of the heat generator must be added to the flow pressure determined from the chart when sizing the gas valve train. Minimum flow pressure 15 mbar.

Minimum 200 kW full-load firing rate for two-stage operation

WGL40

Burner rating	Low-pressure supply (flow pressure in mbar into shutoff valve, p_i max = 300 mbar)					
	W-MF 507	W-MF 512	512	DMV 525/ 12	DMV 5065/ 12	DMV 5080/ 12
[kW]	$\frac{3}{4}$ "	1"	1½"	2"	DN65	DN80

Nat. gas E, LHV = 10.35 kWh/m³ (37.26 MJ/m³), d = 0.606, W_i = 13.295 kWh/m³

200	18	14	13	11	11	11
225	20	15	14	12	11	11
250	22	16	15	12	12	12
275	25	18	16	13	13	13
300	28	19	18	14	14	14
325	32	22	20	16	15	15
375	41	27	24	20	19	19
400	45	29	25	21	20	20
425	48	30	26	21	20	20
450	52	31	26	22	21	20
500	60	34	28	23	21	21
550	69	38	31	24	23	22

Nat. gas LL, LHV = 8.83 kWh/m³ (31.79 MJ/m³), d = 0.641, W_i = 11.029 kWh/m³

200	23	17	16	14	14	14
225	26	18	17	15	15	14
250	29	20	18	16	15	15
275	33	22	19	17	16	16
300	37	24	21	18	17	17
325	42	26	23	20	19	19
375	53	33	29	24	23	22
400	58	35	30	25	24	23
425	63	37	32	26	24	23
450	69	39	33	26	25	24
500	81	44	37	28	26	25
550	94	50	41	31	29	27

LPG*, LHV = 25.89 kWh/m³ (93.20 MJ/m³), d = 1.555, W_i = 20.762 kWh/m³

200	10	9	8	–	–	–
225	12	10	9	–	–	–
250	13	11	10	–	–	–
275	15	12	12	–	–	–
300	17	14	13	–	–	–
325	20	15	15	–	–	–
375	25	19	18	–	–	–
400	27	21	20	–	–	–
425	29	21	20	–	–	–
450	30	22	20	–	–	–
500	34	24	22	–	–	–
550	38	26	23	–	–	–

The LHV is referenced to 0 °C and 1013 mbar atmospheric.

All pressures are in mbar.

* The LPG charts are based on propane, but may also be used for butane.

Please note that an FRS regulator is required at additional cost for gas connection pressures > 150 mbar.

Order numbers

Extra equipment

Burner

Burner type	Version	Operation		Valve train		Order No.
		Natural gas / LPG	Gas oil	R / DN	Type	
WGL30/1-C	ZM	Sliding-two-stage / modulating	Two-stage	¾"	W-MF 507 SE	235 316 21
		Sliding-two-stage / modulating	Two-stage	1"	W-MF 512 SE	235 316 31
		Sliding-two-stage / modulating	Two-stage	1½"	W-MF 512 SE	235 316 41
WGL40/1-A	ZM	Sliding-two-stage / modulating	Two-stage	¾"	W-MF 507 SE	235 416 21
		Sliding-two-stage / modulating	Two-stage	1"	W-MF 512 SE	235 416 31
		Sliding-two-stage / modulating	Two-stage	1½"	W-MF 512 SE	235 416 41
		Sliding-two-stage / modulating	Two-stage	2"	DMV 525/12	235 416 61
		Sliding-two-stage / modulating	Two-stage	DN65	DMV 5065/12	235 426 31
		Sliding-two-stage / modulating	Two-stage	DN80	DMV 5080/12	235 426 41

Extra equipment

Description	Order No.		
	WGL30	WGL40	
Additional ¾" FRS governor for gas supply pressures > 150 mbar	230 011 04	230 011 05	
Additional 1" FRS governor for gas supply pressures > 150 mbar	230 011 63	230 011 63	
Additional 1½" FRS governor for gas supply pressures > 150 mbar	230 011 64	230 011 64	
W-MF 507 with 1" ball valve & TAE for TRGI	230 010 92	230 010 92	
Combustion head extension	by 100 mm	230 010 36	230 010 80
	by 200 mm	230 010 37	230 010 81
	by 300 mm	230 010 38	-
Solenoid valve for air pressure switch test for continuous-run fan or post-purge	230 010 46	230 010 46	
Air inlet flange for duct connection, with air pressure switch	230 010 32	230 008 36	
Burner rotated through 180°	230 010 28	230 010 28	
W-FM25 O2 combustion manager for O2 trim	230 012 36	230 012 36	
GW50 high gas pressure switch with connection cable and plug for valve trains ≤ 1½", supplied loose	230 011 42	230 011 42	
GW50 high gas pressure switch with connection cable and plug for valve trains ≥ 2", supplied loose	-	230 011 43	
O2 trim set, comprising O2 module, O2 probe, probe flange, and connection cables with plugs	230 012 34	230 012 34	
EM 3/3 analogue expansion module	230 011 51	230 011 51	
EM 3/2 field bus expansion module (Profibus / Modbus-RTU)	230 011 52	230 011 52	
Remote reset	230 011 48	230 011 48	

Please enquire regarding other items of extra equipment

Technical data

Dimensions

Technical data

Burner type	Combustion manager	Fan motor	Pump motor	Actuator / Oil pump	Monitoring	Burner mass ^①	Gas valve train		Mass ^①	Noise emission ^②
							Size	Type		
WGL30/1-C	W-FM25	ECK 05/A-2 230 V; 50 Hz Cap. 12 µF 2.3 A; 380 W 2890 rpm	ECK 02/F-2P 230 V; 50 Hz Cap. 3 µF 0.63 A; 75 W 2810 rpm	STE 4,5 * BO.36/6-01L ————— ALV 65 C 75 l/h	Air pressure LGW 10A2 Flame FLW	39 kg	¾"	W-MF 507 SE	6.0 kg	72 dB(A)
							1"	W-MF 512 SE	9.0 kg	
							1½"	W-MF 512 SE	11.5 kg	
WGL40/1-A	W-FM25	ECK 06/A-2 230 V; 50 Hz Cap. 16 µF 3.2 A; 530 W 2900 rpm	ECK 02/F-2P 230 V; 50 Hz Cap. 3 µF 0.63 A; 75 W 2810 rpm	STE 4,5 * BO.36/6-01L ————— ALV 65 C 75 l/h	Air pressure LGW 10A2 Flame FLW	47 kg	¾"	W-MF 507 SE	5.5 kg	73 dB(A)
							1"	W-MF 512 SE	9.0 kg	
							1½"	W-MF 512 SE	13.5 kg	
							2"	DMV 525/12	17.5 kg	
							DN65	DMV 5065/12	50.0 kg	
							DN80	DMV 5080/12	67.0 kg	

① All masses are approximate.

② Measured sound pressure level – Values in the field are subject to variation according to the characteristics of the entire acoustic system.

Burner dimensions

Burner type	Dimensions in mm															
	l ₁	l ₂	l ₃	l ₄	b ₁	b ₂	b ₃	h ₁	h ₂	h ₃	d ₁	d ₂	d ₃	d ₄	R _p	α°
WGL30	169	480	62	197	420	226	196	460	342	226	127	M8	170–186	130	1½"	45°
WGL40	235	577	72	235	450	245	207	480	360	245	154	M10	186–200	160	1½"	45°

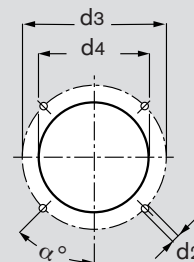
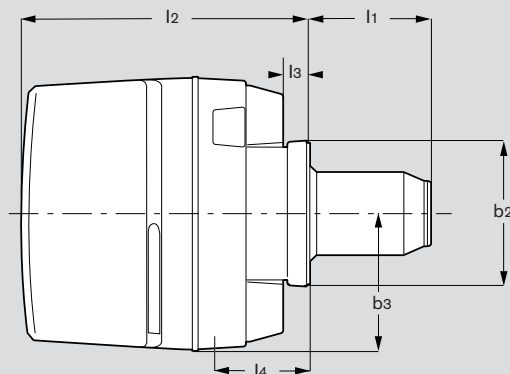
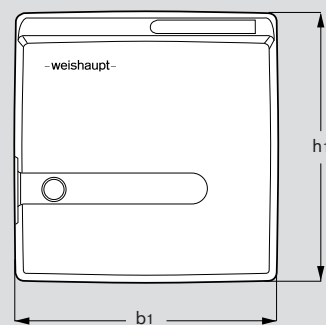
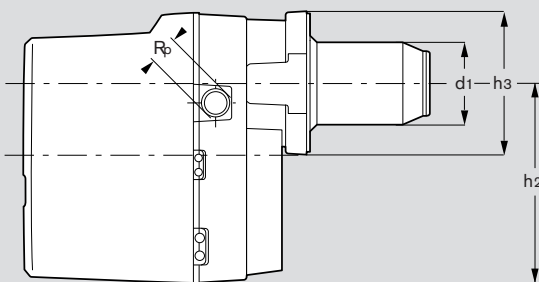

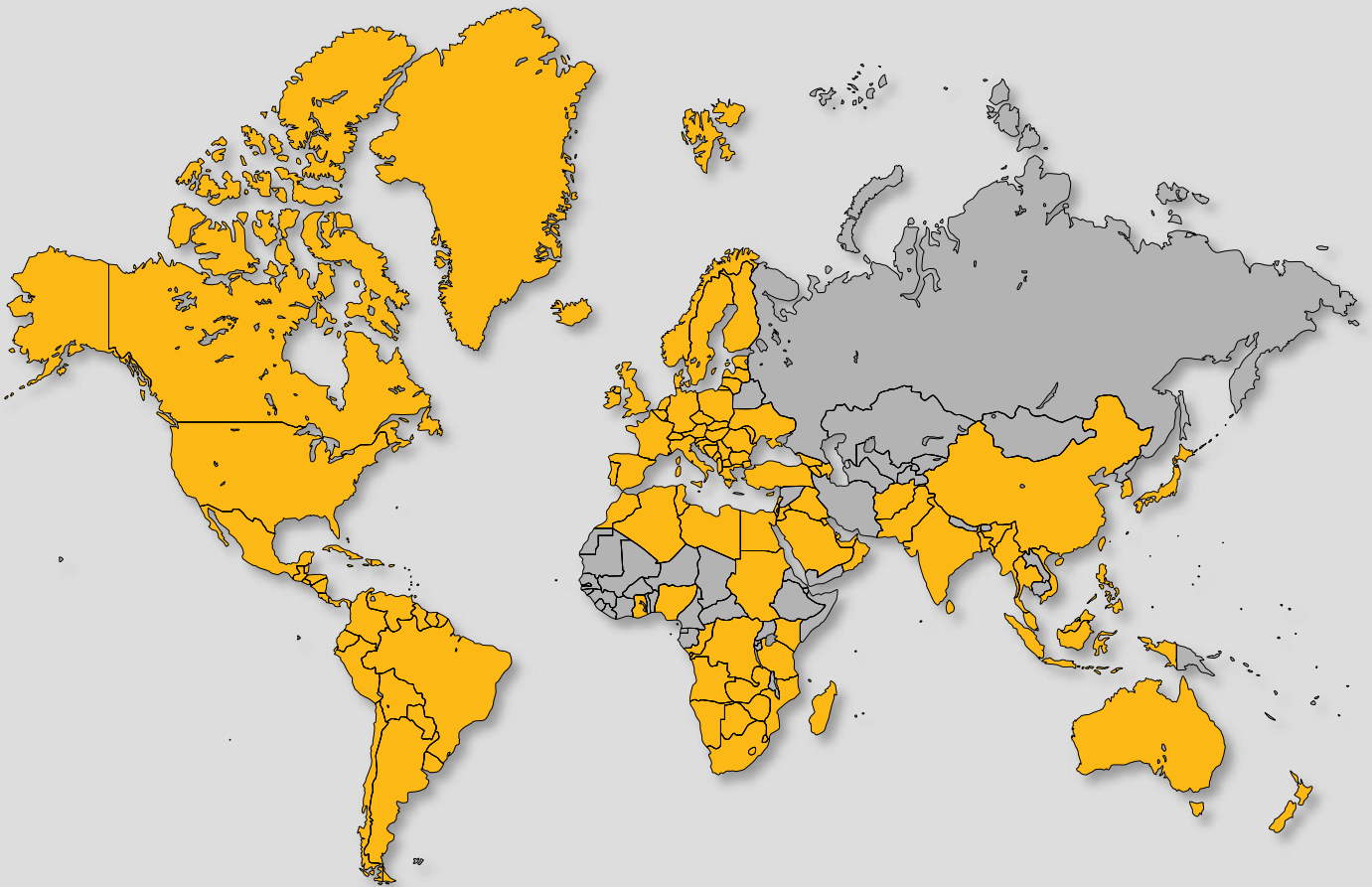

Weishaupt worldwide:

Afghanistan	Canada	Estonia	Indonesia	Liechtenstein	New Zealand	San Marino	Tunisia
Algeria	Chile	Eswatini	Iraq	Lithuania	Nicaragua	Saudi Arabia	Turkey
Angola	China	Faroe Islands	Ireland	Luxembourg	Nigeria	Serbia	UAE
Argentina	Columbia	Finland	Israel	Madagascar	North Macedonia	Singapore	Ukraine
Australia	Congo (D. Rep.)	France	Italy	Malaysia	Norway	Slovakia	United Kingdom
Austria	Congo (Rep.)	French Guiana	Jamaica	Malta	Oman	Slovenia	Uruguay
Bahrain	Costa Rica	Germany	Japan	Mauritius	Pakistan	South Africa	USA
Bangladesh	Croatia	Ghana	Jordan	Mexico	Panama	Spain	Vatican City
Belgium	Cuba	Greece	Kenya	Moldova	Paraguay	Sri Lanka	Venezuela
Belize	Cyprus	Greenland	Korea (S.)	Monaco	Peru	Sudan	Vietnam
Bolivia	Czechia	Guatemala	Kosovo	Montenegro	Philippines	Suriname	Zambia
Bosnia-Herzegovina	Denmark	Guyana	Kuwait	Morocco	Poland	Sweden	Zimbabwe
Botswana	Dominican Rep.	Haiti	Lebanon	Mozambique	Portugal	Switzerland	
Brazil	Ecuador	Honduras	Lesotho	Myanmar	Puerto Rico	Taiwan	
Bulgaria	Egypt	Hungary	Libya	Namibia	Qatar	Tanzania	
	El Salvador	India		Netherlands	Romania	Thailand	