

Technical information
Marine burners (MFO)

–weishaupt–

Capacities up to 11 MW
for shipping and offshore installations

Marine
burners

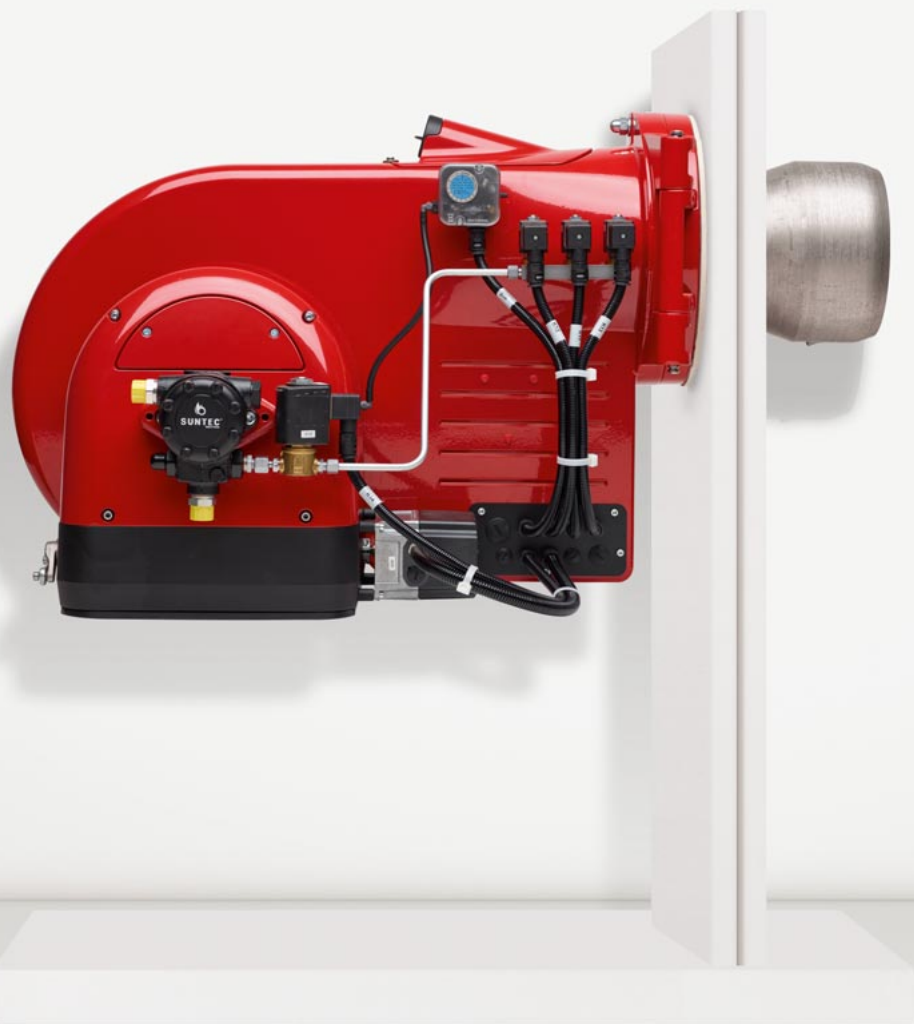

Progress and tradition



*Weishaupt products can be found anywhere
that reliability is essential*

For decades, Weishaupt has designed and produced marine burners for a wide range of applications, such as auxiliary and hot-water boilers for ships or offshore installations. Weishaupt's in-house Research and Development Centre is constantly working on innovative new developments.

The burners are notable for their robust and compact design, and for being easy to install and service. Particular care was taken during development to ensure a maintenance-friendly design.

The commitment to quality goes beyond the burner and its servicing. Weishaupt offers individual solutions for fuel trains and for the control of burners, boilers, and their services. Weishaupt is your one-stop shop for expertise.

Modular.

Digital combustion management makes the operation of combustion plant both convenient and safe. All essential functions, such as flame monitoring and the regulation of fuel and air are effected and controlled with digital precision.

Robust.

The robust, compact construction of Weishaupt's marine burners has proven itself under the harshest of conditions over many decades.

Reliable.

The utmost quality is our goal. Thus each burner undergoes extensive testing and is individually inspected by a Classification Society.



Equipped for all ports in the world:

A Weishaupt burner for almost any fuel. There are various qualities of marine fuel oil (MFO). MARPOL 73/78 Annex I to VI regulates the use and the emission of sulphurous combustion products in certain sea areas. This has resulted in the production of non-standard, reduced-sulphur oils.

The ISO 8217 standard for marine fuels differentiates between distillate fuel oils (MDF) and residual fuel oils (RFO). The most important specifications limit the density, viscosity, water content, and flash point of the oil.

MARPOL regulations stipulate that a sample of each fuel delivered must be available on board. The fuel may only be used once the fuel specification (Bunker Delivery Note) has been approved by the test laboratory.

Weishaupt burners in marine execution are suitable for use with marine fuel oils that are compliant with DIN ISO 8217:2018-10 and ISO 8017:2017-03 (please enquire regarding the suitability of other fuels).

For safety reasons, due to its low flash point of 45 °C, DMX-quality oil is not approved for combustion on board ships.

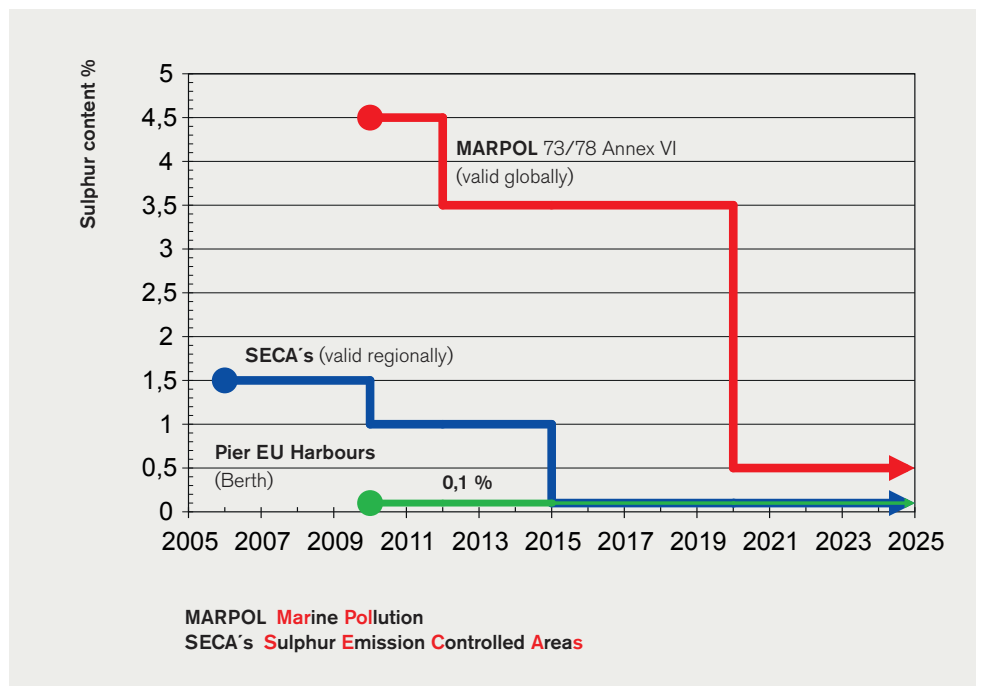

Limit values for sulphur content in the fuel

Source: DIN ISO 8217 : 2018-10 ISO 8217 : 2017-03			Marine fuel oils (MFO)														
Commercial designations			Distillate oils (MDF) e.g. MGO / MDO*				Residual oils (RFO) e.g. HFO* / Bunker oil*										
Characteristics	Unit	Limit	DMX	DMA	DMZ	DMB	RMA	RMB	RMD	RME	RMG				RMK		
			¹⁾	DFA	DFZ	DFB	10	30	80	180	180	380	500	700	380	500	700
Viscosity at 40 °C / 50 °C	mm ² /s	min.	1.4	2.0	3.0	2.0											
		max.	5.5	6.0	6.0	11.0	10.0	30	80	180	180	380	500	700	380	500	700
Density at 15 °C	kg/m ³	max.	–	890	890	900	920	960	975	991	991				1010		
Sulphur	mass %	max.	1.0	1.0	1.0	1.5	Statutory requirements										
Flash point	°C	min.	43	60	60	60	60	60	60	60	60				60		
Hydr. sulphide	mg/kg	max.	2.0	2.0	2.0	2.0	2.0	2.0	2.0	2.0	2.0				2.0		
Carbon residue	mass %	max.	–	–	–	0.3	2.5	10	14	15	18				20		
Pour point	winter °C	max.	–	-6	-6	0	0	0	30	30	30				30		
	summer °C	max.	–	0	0	6	6	6	30	30	30				30		
Water	vol %	max.	–	–	–	0.3	0.3	0.5	0.5	0.5	0.5				0.5		
Fatty acid methyl- ester (FAME)	vol %	max.	–	7	7	7	–	–	–	–	–				–		
Weishaupt guide values for the atomising temperature °C			20-40	20-40	20-50	60	90	115	135	135	150	155	160	150	155	160	
Application range for Weishaupt burner			Distillate oil burners ²⁾				MS ³⁾ burners (two-stage)								MS ³⁾		
							MS ³⁾ burners (two-stage) with fuel-changeover operation										
							RMS ³⁾ burners (sliding-two-stage / modulating)										
							RMS ³⁾ burners (sliding-two-stage / modulating) with fuel changeover operation										

¹⁾ DMX not approved for marine burner operation ²⁾ WM-L burners: three-stage / modulating distillate-oil burners

³⁾ MS/RMS burners: multi-stage / modulating residual-oil burners

















Fully approved

Weishaupt burners meet Classification Society specifications.

Classification Societies create the technical regulations by which ships and offshore installations must abide, and monitor and document compliance with them.

Internationally recognised Classification Societies

IACS International Association
of Classification Societies

ABS	American Bureau of Shipping		
BV	Bureau Veritas		
CCS	China Classification Society		
DNV	Det Norske Veritas Germanischer Lloyd		
KR	Korean Register of Shipping		
LR	Lloyd's Register of Shipping		
PRS	Polish Register of Shipping		
RINA	Registro Italiano Navale		

As at January 2024

Burners and components that are approved for use in shipping and in offshore installations **type approval**. This approval is the basis of the final approval that takes place either at the test facility or on site.

Type Approval			
Classification	Country	Approval Code No.	Product
ABS	USA	23-2381861-PDA	M / MS / RMS / 1-8 EV2/WEV
		23-2407363-PDA	WM-L10/1-30/2, version T WM-L10/2-50/2, version R
BV	France	52206/BO BV	M / MS
		52208/BO BV	RMS
		74525/AO BV	WM-L10/1-30/2, version T WM-L10/2-50/2, version R
CCS	China	Service agreement	
DNV	Norway	TAP000022JZ	WM-L10/1-30/2, version T WM-L10/2-50/2, version R
		TAP00002HW	M / MS / RMS 1-8 and 50-70
		TAP00002HK	EV2 / WEV
KR	Korea	HMB04961-BR001	MS / RMS 5-8
LR	UK	Service agreement	In Progress
PRS	Poland	TE/1111/815893/23	M / MS / RMS 1-8
RINA	Italy	MAC 220223XG	WM-L10/1-30/2, version T WM-L10/2-50/2, version R

Other classifications can be met on request

The burner can be matched to the ship via the registration code.



Registration code on the burner's flange

Shipowners are not legally obliged to classify their ships. However, very few states permit the operation of unclassified vessels within their territorial waters, so classification is virtually unavoidable if a ship is to be given as wide an operating range as possible.

Ships without classification are not permitted in European waters or ports.

The Plimsoll line, as it is known, shows by which society the ship has been classified. On merchant ships, the mark is found halfway along both sides of the hull.



The Plimsoll line identifies the Classification Society

You have a demanding requirement: Weishaupt has a suitable burner

Step by step to your tailor-made burner

We need the following information from you to select your burner:

1. Type of marine fuel	2. Boiler make / model and construction (furnace geometry)	3. Installed position of the burner	4. Type of load control required	5. Classification required
<ul style="list-style-type: none"> ▪ DMA ▪ DMZ ▪ DMB ▪ RMA ▪ RMB ▪ RMD ▪ RME ▪ RMG ▪ RMK 	<ul style="list-style-type: none"> ▪ Heating and hot water (LTHW / HTHW / steam) ▪ Auxiliary boiler (steam / thermal fluid) ▪ Process plant (e.g. oil treatment) 	<ul style="list-style-type: none"> ▪ Horizontal ▪ Horizontally inclined (10–30°) ▪ Vertical 	<ul style="list-style-type: none"> ▪ Multi-stage T / M / MS <ul style="list-style-type: none"> – (viscosity up to 500 mm²/s at 50 °C) – (viscosity up to 380 mm²/s at 50 °C when alternating with MGO) ▪ Modulating R / RMS <ul style="list-style-type: none"> – (viscosity up to 700 mm²/s at 50 °C) 	<ul style="list-style-type: none"> ▪ ABS ▪ BV ▪ CCS ▪ DNV ▪ KR ▪ LR ▪ PRS ▪ RINA



Available classifications:

- ABS
- BV
- CCS (exclusively with factory acceptance test)
- DNV
- LR (Market launch 2024/2nd quarter)
- RINA

For distillate oils (DM...)

Type

Capacity range* (Partial load ■) Full load ■

WM-L10/1-A version T	■ (70) 120–405 kW
WM-L10/2-A versions T and R	■ (150) 230–600 kW
WM-L10/3-A versions T and R	■ (250) 430–800 kW
WM-L10/4-A versions T and R	■ (325) 550–1 120 kW
WM-L20/1-A versions T and R	■ (400) 600–1 400 kW
WM-L20/2-A versions T and R	■ (600) 1 020–2 100 kW
WM-L20/3-A versions T and R	■ (800) 1 380–2 600 kW
WM-L30/1-A versions T and R	■ (800) 1 270–3 100 kW
WM-L30/2-A versions T and R	■ (900) 1 600–4 100 kW
WM-L30/3-A version R	■ (1 100) 2 300–5 700 kW
WM-L50/1-A version R	■ (1 200) 2 000–8 000 kW
WM-L50/2-A version R	■ (1 750) 4 000–11 000 kW

Oil burners

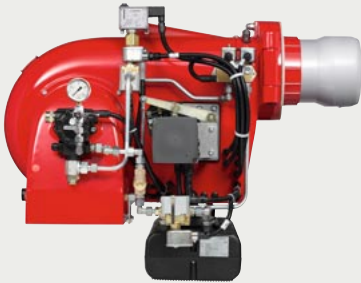

For residual oils (RM...)

Type	Capacity range* (Partial load ■) Full load ■
M1	■ (90) 180–415 kW
M3	■ (120) 300–775 kW
M5	■ (225) 500–1 190 kW
MS/RMS7	■ (450) 750 / 800–1 965 kW
MS/RMS8	■ (675) 1 300–2 740 kW
MS/RMS8/2	■ (675) 1 600–3 155 kW
RMS50	■ (1 125) 2 300–6 170 kW
RMS70 ¹⁾	■ (2 025) 4 700–10 900 kW

¹⁾ A separate oil pump station is required for each fuel

For distillate oils (DM...) and residual oils (RM...) in alternation

(oil-side adjustment is not required)

Type	Capacity range* (Partial load ■) Full load ■
MS/RMS7	■ (450) 750 / 800–1 965 kW
MS/RMS8	■ (675) 1 300–2 740 kW
RMS50 ¹⁾	■ (1 125) 2 300–6 170 kW
RMS70 ¹⁾	■ (2 025) 4 700–10 900 kW

¹⁾ A separate oil pump station is required for each fuel

* The burner must be correctly sized for the combustion chamber resistance and geometry. Refer to the capacity chart in the burner sales brochure / manual.

For greater outputs or for duobloc burners, please enquire.

Weishaupt burners offer many benefits

Weishaupt burners are made to order. Consequently, you receive a product tailor-made to your requirements.

Reliable, convenient fuel changeover

A wide variety of fuel combinations are possible with a Weishaupt dual-fuel or triple-fuel burner. Changing over from gas (LNG or LPG) to oil is just as straight-forward as changing over from a higher to a lower-viscosity oil. Regardless of the type of fuel changeover required, we have the right solution.

Tried-and-tested components with innovative details serve to improve burner performance, operation, and safety. One particular key benefit of Weishaupt equipment is the use of the UHE-WH multi-fuel pump. It eliminates the need to make adjustments to atomisation pressure when burner operation is alternating between different oils.

The burner's oil supply needs to maintain thermal balance, particularly when changing over from a high-viscosity residual oil to a low-viscosity distillate oil. If the difference in viscosity is great, however, then this is not possible. It therefore becomes necessary to use an auxiliary fuel during the changeover process to help stabilise viscosity.

Oil pressure monitoring, which is included as standard, allows the oil flow to be monitored, another example of how Weishaupt increases safety.

Weishaupt's goal is and always has been the development of burners and fuel supply systems that go above and beyond normal standards.



A guided oil drip pipe ensures maximum safety (standard for burners with alternating-oil executions)

Guided oil drip pipe for maximum safety

Alternating between different marine oils exposes the pump shaft seal to a lot of mechanical stress. Despite good filtering, residual oils contain particulates that corrode the surface of the seal. Very low oil viscosities are briefly present when changing over to distillate oil. Under these conditions, the shaft seal can no longer seal completely and, as a consequence, there is a minimal amount of oil leakage.

The UHE-WH multi-fuel pump offered by Weishaupt is an innovative solution to this problem. High-quality materials and a guided oil drip pipe prevent oil from getting into the burner's air inlet area. Another win for safety and operational readiness.

Air/gas separator improves burner performance and saves energy

Spill-back-type oil nozzles unavoidably introduce air into the oil supply system. If this air makes its way back to the pump then pressure fluctuations and flame instability will result. The air/gas separator is an effective component that prevents this happening. A further advantage of the air/gas separator is



Integral air/gas separator for greater operational reliability and convenience (standard for RMS burners with alternating-oil executions)

that it acts as a low-loss header. It separates the transfer circuit from the burner circuit and provides for different temperature zones. This reduces the load on the oil preheater and allows it to be optimally sized, thereby saving energy and reducing operational costs.

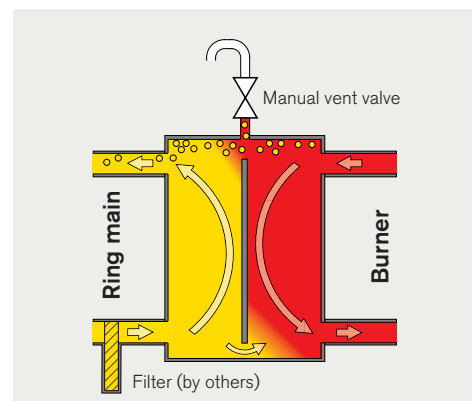

Separation into different temperature zones saves energy and reduces costs

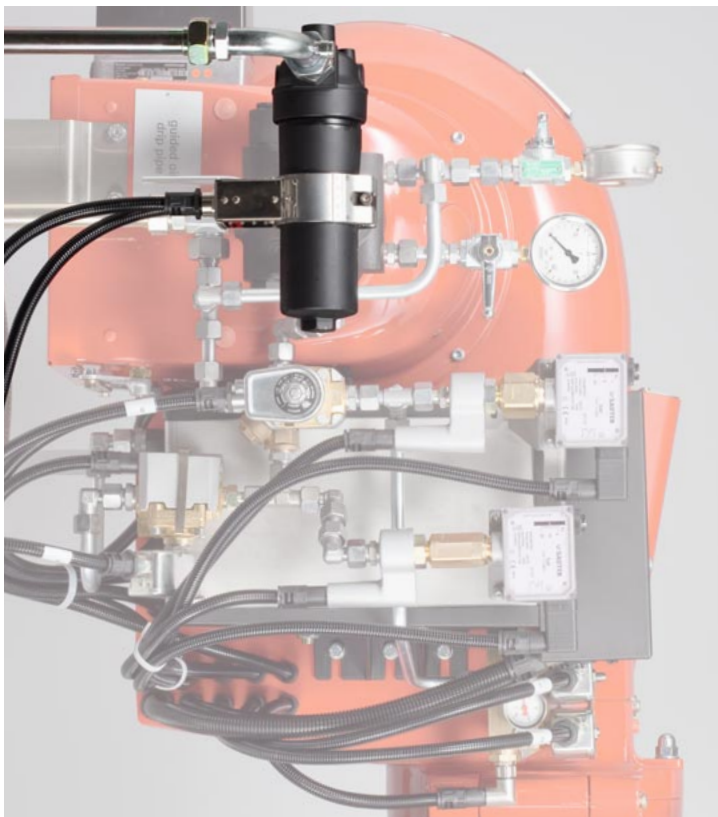

The flexible design of the heated oil filter enables the burner to be installed in any desired position, from horizontal to vertical



*The integral oil filter is readily accessible
(Supplied as standard on MS burners in alternating-oil execution)*

Oil filter fitted as standard

The burner's heated, integral oil filter is readily accessible and easy to service. The filter's flexible design enables the burner to be positioned as required.

Increased safety during servicing

The burner hinge stay, which is supplied as standard, ensures that the burner cannot swing closed during servicing.

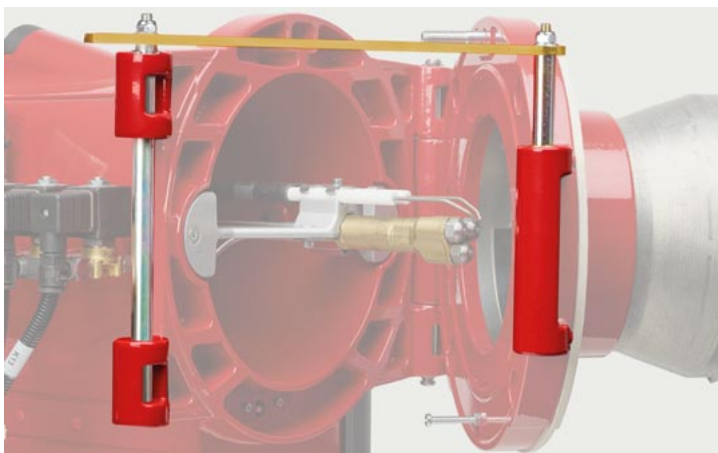

WM-L burners

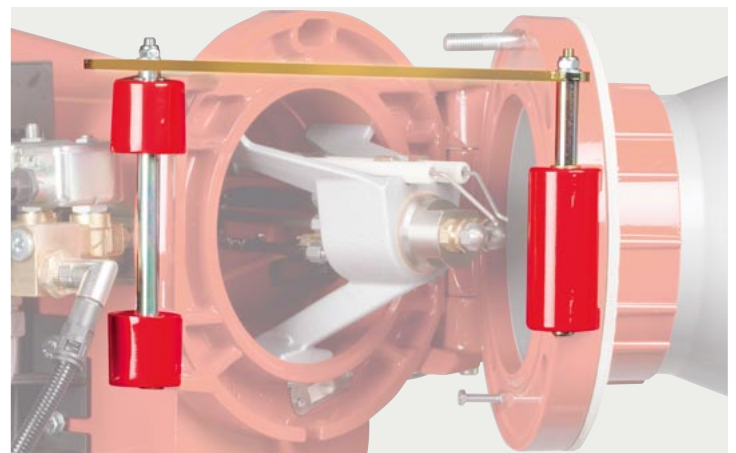

MS burners

The controls you need:

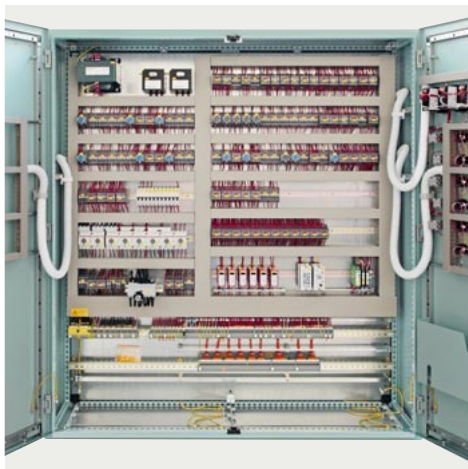

Weishaupt's control systems will meet all of your Classification Society's particular requirements and are available in all of the usual voltages and frequencies



Fully redundant controls for maximum safety

Digital combustion management offers:

- Digital precision
- Reproducible setpoints
- Ease of use
- Flexible communication
- Data backup / fault analysis
- Menu-driven, clear-text display

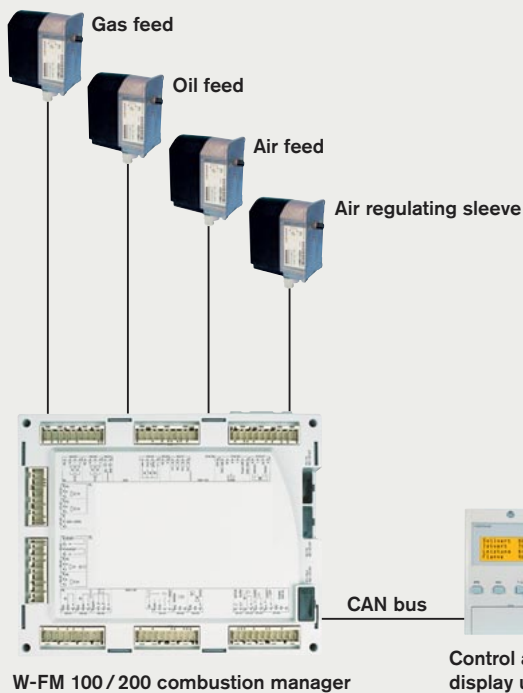

PC / touchscreen visualisation



System networking via PLC / DDC

Digital combustion management makes WM-L burner operation convenient and safe

Simple, time-saving conversions with ready-to-install conversion kits

Ready-to-install conversion kits

The introduction of stricter emission limits has made it necessary to convert burners that previously fired only residual oil so that they can now also fire distillate oil when required. Weishaupt offers ready-to-install conversion kits, which provide a simple and time-saving means of adapting the burner to the different requirements.



Conversion kit for RMS7/RMS8



Conversion kit for MS7/MS8 Z

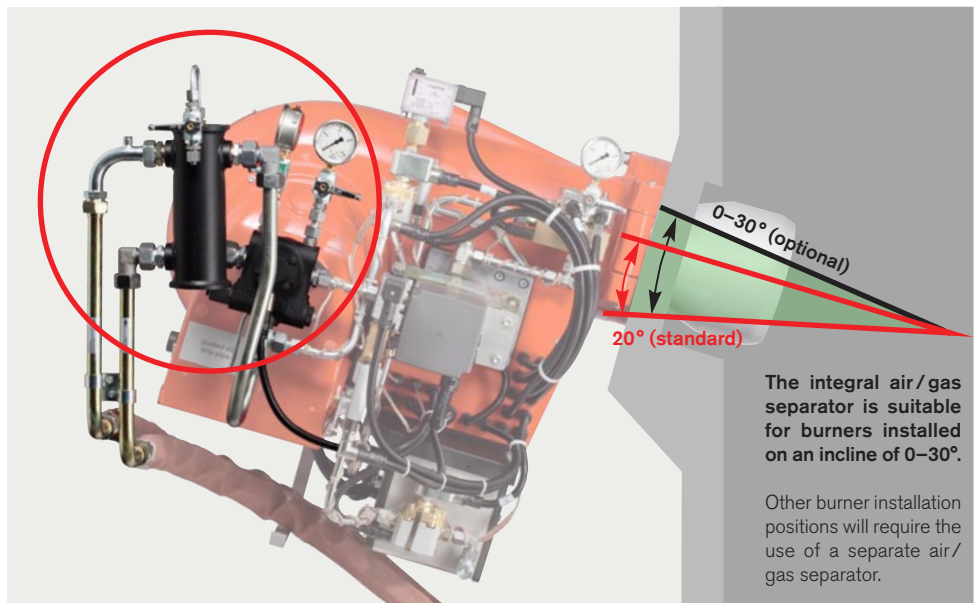

Ready-to-install conversion kits simplify the conversion of an existing burner and are easy to install (Example: RMS7/RMS8)

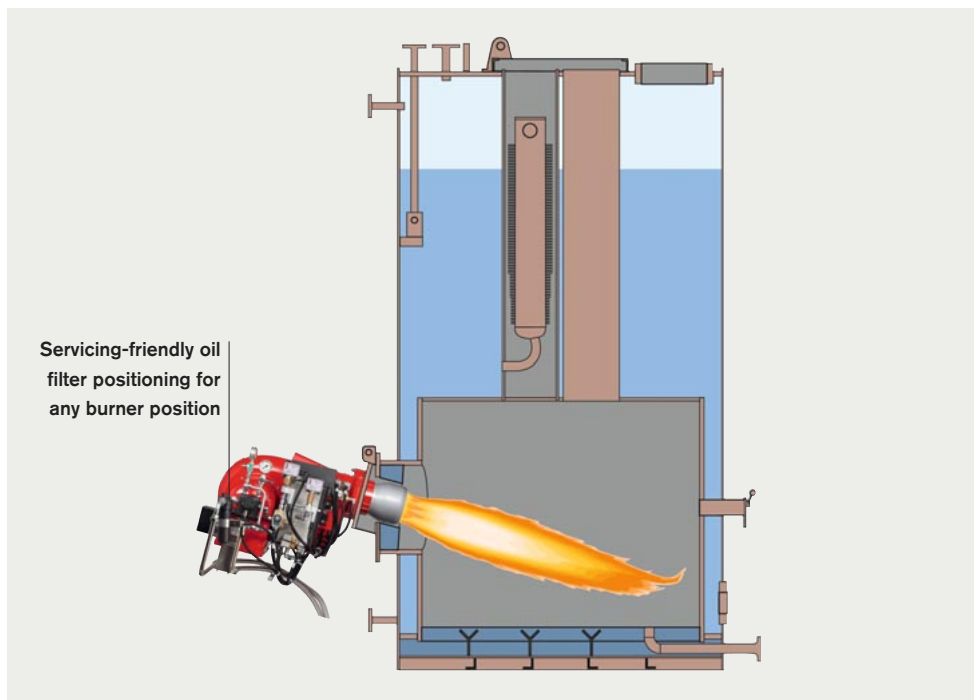

The MS conversion kit allows burner installation in any position from horizontal to vertical (example: MS7/MS8)

Fuel supply and changeover

Distillate oil (DM...)

WM-L burners (three-stage)

- | | |
|--|---------------------------------|
| ① Transfer pump (redundant) | ⑩ Temperature switch (40–60 °C) |
| ② Air / gas separator | ⑪ Linked ball valves |
| ③ Low oil pressure switch | ⑫ Oil filter |
| ④ Pressure regulating valve | ⑬ Burner pump |
| ⑤ Three-way ball valve (return) | ⑭ Strainer |
| ⑥ Three-way ball valve (supply) | ⑮ Solenoid valve |
| ⑦ Venting vessel | ⑯ Oil preheater |
| ⑦a Cooler (20–40 °C) for operation with viscosities < 3mm ² /s at 40 °C | ⑰ Temperature monitor / switch |
| ⑧ Three-way ball valve (DM.../DM...) | ⑱ Two-stage nozzle assembly |
| ⑨ Heating (60–90 °C) | ⑲ High oil pressure switch |

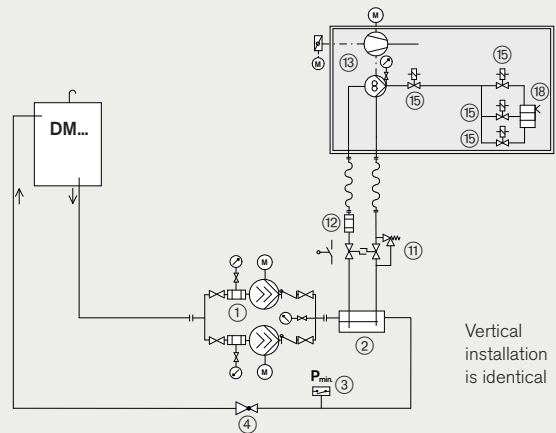

Residual oil (RM...) ¹⁾

MS burners

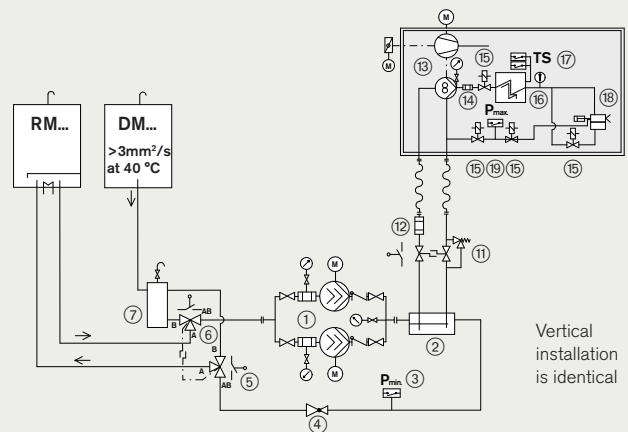

Alternating distillate (DM...) & residual oil (RM...)

MS7–MS8 burners ²⁾

(oil-side adjustment is not required)

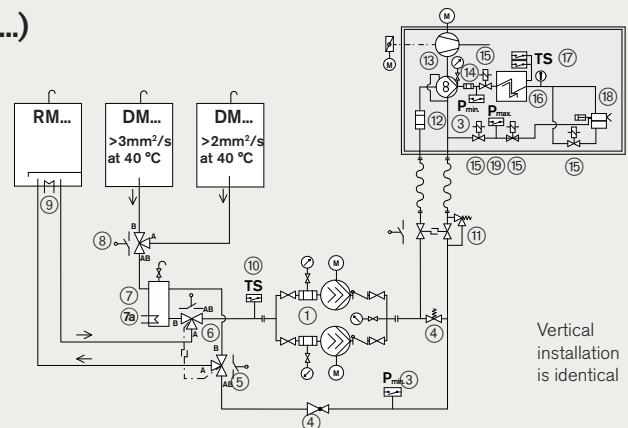

¹⁾ DM... as an auxiliary fuel only, for boiler startup/shutdown and burner purging ²⁾ Burner size 8/2 excluded

Distillate oil (DM...)

WM-L burners (modulating)

- | | |
|--|---------------------------------|
| ① Transfer pump (redundant) | ⑩ Temperature switch (40–60 °C) |
| ② Air / gas separator | ⑪ Linked ball valves |
| ③ Low oil pressure switch | ⑫ Oil filter |
| ④ Pressure regulating valve | ⑬ Burner pump |
| ⑤ Three-way ball valve (return) | ⑭ Strainer |
| ⑥ Three-way ball valve (supply) | ⑮ Solenoid valve |
| ⑦ Venting vessel | ⑯ Oil preheater |
| ⑦a Cooler (20–40 °C) for operation with viscosities < 3mm ² /s at 40 °C | ⑰ Temperature monitor / switch |
| ⑧ Three-way ball valve (DM.../DM...) | ⑱ Two-stage nozzle assembly |
| ⑨ Heating (60–90 °C) | ⑲ High oil pressure switch |
| | ⑳ Oil nozzle assembly solenoid |
| | ㉑ Oil regulator |

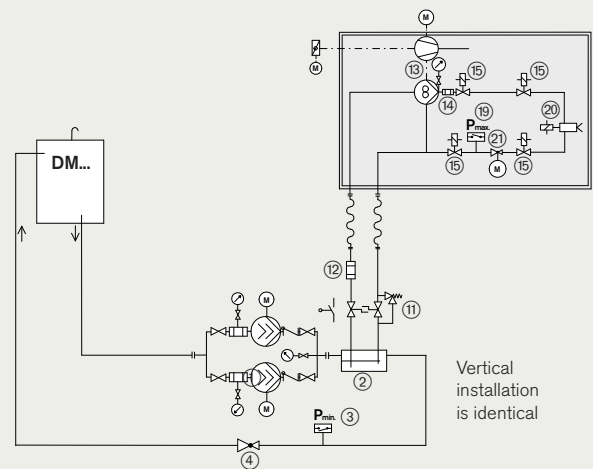

Residual oil (RM...) ¹⁾

RMS7–RMS8 burners

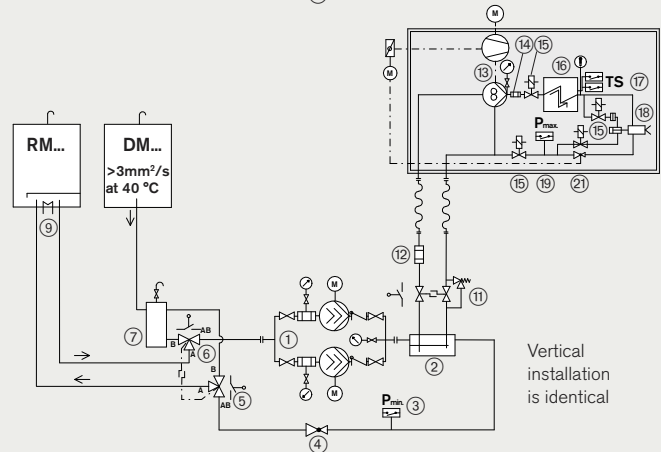

Alternating distillate (DM...) & residual oil (RM...)

RMS7–RMS8 Burners ²⁾

(oil-side adjustment is not required)

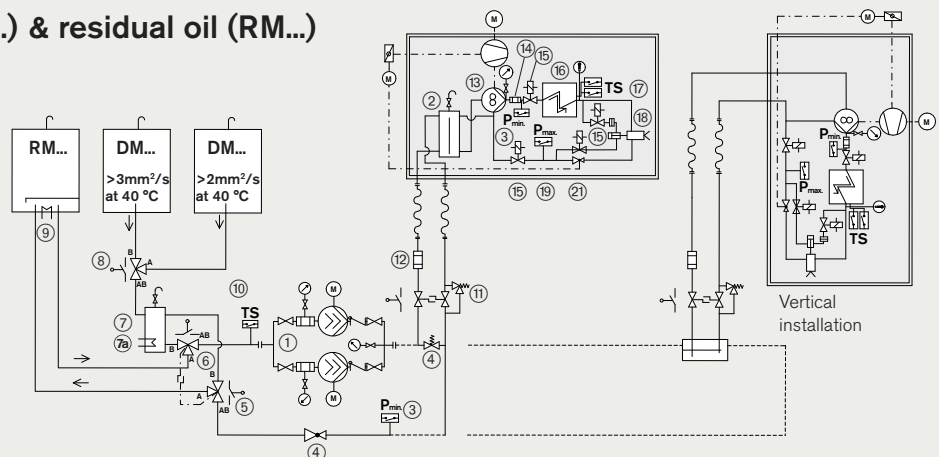

¹⁾ DM... as an auxiliary fuel only, for boiler startup/shutdown and burner purging ²⁾ Burner size 8/2 excluded

Fuel supply and changeover

Changeover between separate distillate oil and residual oil supplies

- | | | |
|---|---------------------------------------|--------------------------------|
| ① Burner for MGO/RFO in alternation | ⑧ Air / gas separator with vent valve | ⑲ High oil pressure switch |
| ② Combustion air fan with damper and actuator | ⑨ High-pressure supply pump | ⑳ Oil nozzle assembly solenoid |
| ③ Linked ball valves with safety valve | ⑩ Non-return valve | ㉑ Oil regulator |
| ③a Three-way changeover valve (MGO/RFO) | ⑪ Ringmain feeder pump | ㉒ Burner pump |
| ③b Three-way changeover valve for RFO purging | ⑫ Air / gas separator | ㉓ Strainer |
| ④ Filter | ⑬ Low oil pressure switch | |
| ⑤ Single-pipe feeder pump | ⑭ Ringmain pressure gauge | |
| ⑥ Oil meter | ⑮ Solenoid valve | |
| ⑦ Shutoff valve | ⑯ High-pressure supply pump | |
| | ⑰ Oil preheater | |
| | ⑱ Ringmain pressure regulating valve | |

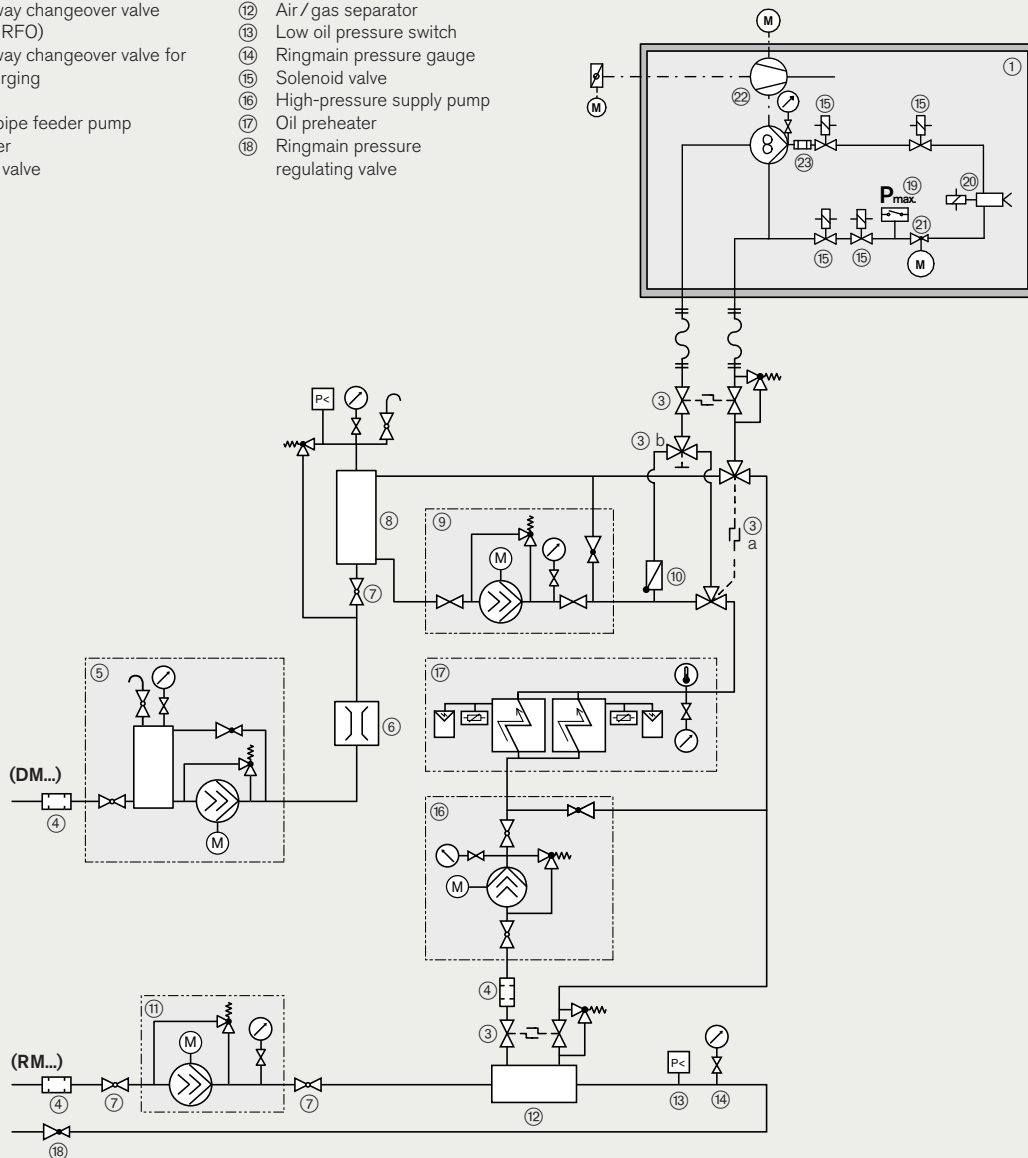

Key dimensions at a glance WM-L10-50

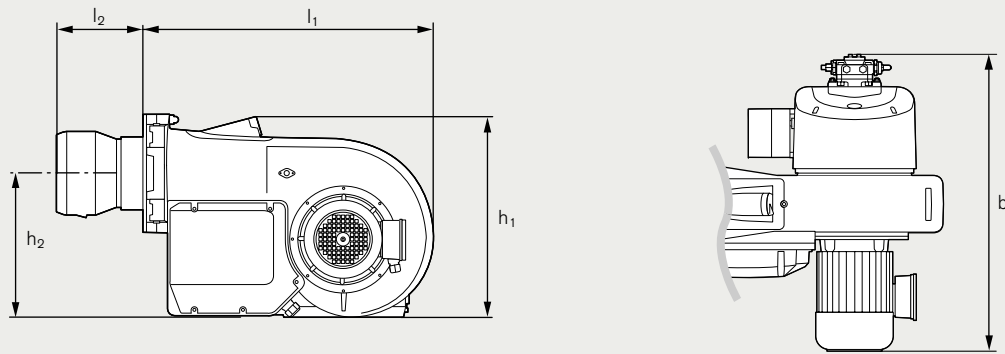

Dimensions

Dimension	WM-L10				WM-L20			WM-L30			WM-L50	
	...10/1	...10/2	...10/3	...10/1-4	...20/1	...20/2	...20/3	...30/1	...30/2	...30/3	...50/1	...50/2
l1	659				810			941	956		1616	1636
l2	118-138	127-147	147-171	148-168	217-232	227-247	237-257	301-326		285-325	442	457
h1	445				573			695	730		1058	1071
h2	313				408			505			758	
b	630	630/659	658/687		835		835/875	989	1028	1042	-/1462	-/1308

Mounting plate drilling dimensions

Dimension	WM-L10		WM-L20			WM-L30		WM-L50	
d3	M10		M12			M12		M16	
d4	165	185	240	260	270	305	375	435	530
d5	186	210	298			330	400	470	580

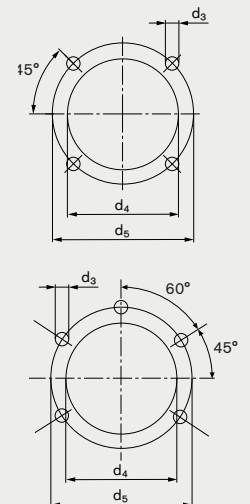

Dimensions in mm

For additional dimensions please refer to the planning handbook and other product documentation.

Dimensions and hinging radii for sizes 7 and 8 MGO-MDO-HFO version

MS 7 oil burner

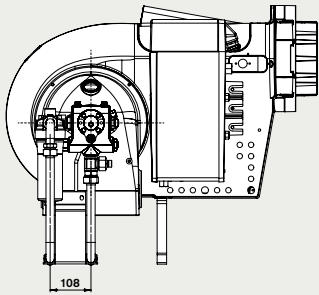

RMS 7 oil burner

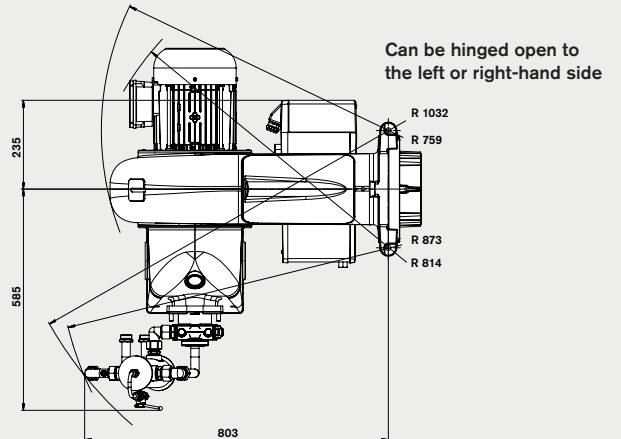
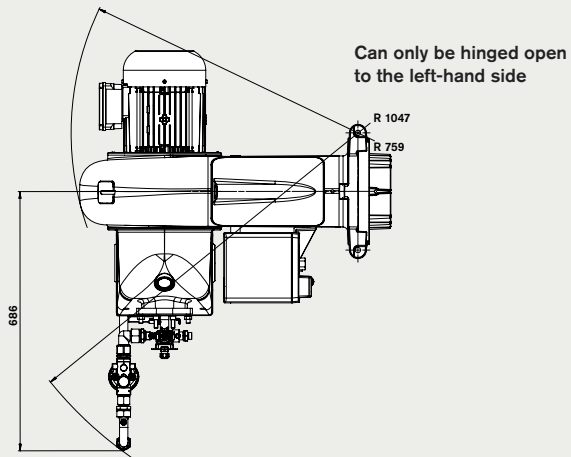
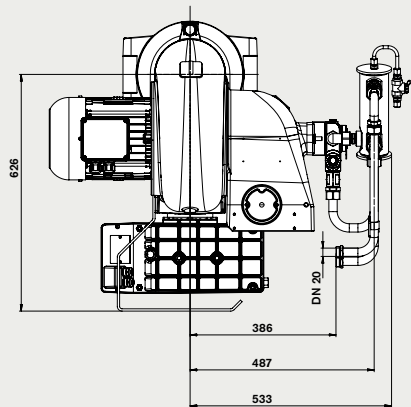
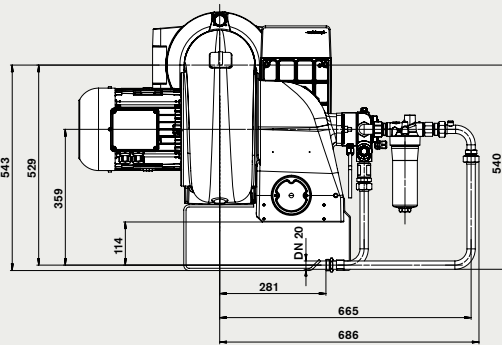
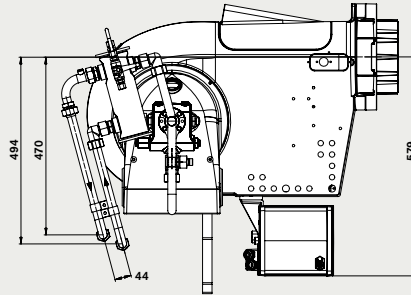

For additional dimensions please refer to other product documentation.

Our suggestion: Weishaupt- recommended equipment

Equipment	ABS	BV	CCS	DNV	KR	LR	PRS	RINA
Burner, general								
Marine specification	•	•	•	•	•	•	•	•
	<ul style="list-style-type: none"> All burner castings painted internally Motor terminal box sealed with captive screws Cables protected by flame-retardant hose Marine cable glands in accordance with DIN 89280 Type-tested, stainless-steel oil hoses Hinge stay for servicing works Oil pressure gauge with ball valve 							
Optional	•	•	•	•	•	•	•	•
	<ul style="list-style-type: none"> Spheroidal cast iron or cast steel oil filter 							
Control								
Controller / combustion manager	•	•			•	•	•	•
			•	•				
	•	•	•	•		•	•	•
	<ul style="list-style-type: none"> W-FM100/200 fitted at the burner (WM-L) 							
Flame sensor			•					
	•	•		•	•	•	•	•
	•	•	•	•		•	•	•
	<ul style="list-style-type: none"> QRI (in conjunction with W-FM100/200) 							
Air pressure	•	•	•	•		•	•	•
	•	•	•	•		•	•	•
	<ul style="list-style-type: none"> LGW switch LGW switch (WM-L) 							
Motor	•	•	•	•		•	•	•
	•	•	•	•		•	•	•
	<ul style="list-style-type: none"> Direct on line starter fitted at the motor (WM-L 10-20) Star/delta starter fitted at the motor (WM-L 30-50) 							
Oil pump								
Integral oil pump	•	•	•	•	•	•	•	•
	<ul style="list-style-type: none"> Low oil pressure switch (MGO-MDO-RFO version) High oil pressure switch (MS / RMS burners) 							
External oil pump	•	•	•	•	•	•	•	•
	<ul style="list-style-type: none"> Air pressure switch Low oil pressure switch in oil supply 							
Component heating								
RFO version	•	•	•	•	•	•	•	•
	<ul style="list-style-type: none"> Oil solenoid valves / oil pressure switch, 22 W Nozzle assembly, 110 W Oil regulator, 22W (on RMS burners) Burner-mounted filter, 2x 66 W 							
Oil pump	•	•	•	•	•	•	•	•
	<ul style="list-style-type: none"> E4-7 80W, T/TA/UHE-WH.. 110W 							
500–700 mm ² /s at 50 °C	•	•	•	•	•	•	•	•
	<ul style="list-style-type: none"> Heated oil line and oil distributor, 22W Heated oil hoses, 62W 							

Please enquire regarding equipment for other classification societies.

Weishaupt burners wherever quality is indispensable



A 1.2 MW Weishaupt burner provides heat on the Polarstern research vessel



A 3 MW Weishaupt residual oil burner provides heat for the thermal fluid heater

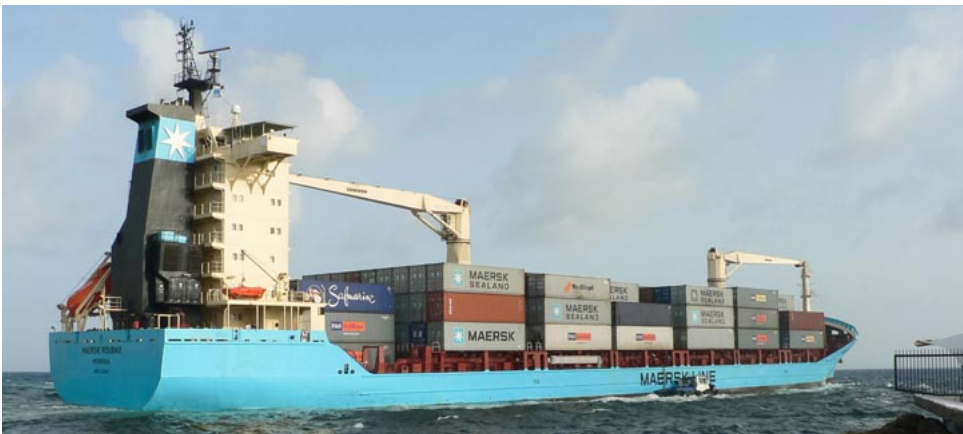

Container ship equipped with a 2.8 MW residual oil burner

At home on the seven seas

The demands on marine applications are high. The very utmost degree of reliability and operational safety is therefore imperative.

Our decades of experience, coupled with the highest quality of product and service, makes us one of the world's leading companies in the industry.

Weishaupt marine burners are used around the globe under the harshest of conditions. For example, they can be found on:

- Cruise ships
- Ferries
- Tankers
- Container ships
- Bulk carriers
- Offshore platforms
- Drilling rigs

Applications:

- Auxiliary and hot-water boilers
- Process plant, such as
 - Waste incineration
 - Oil treatment

Crude oil from rigs in the South China Sea is stored temporarily on central ship depots



Four 10 MW burners on thermal fluid heaters ensure the crude oil can be pumped



Two 10 MW burners with digital combustion management provide the necessary process heat on the oil production platform CNOOC LUDA 27-2



Our recipe for success: Innovation and the latest production methods

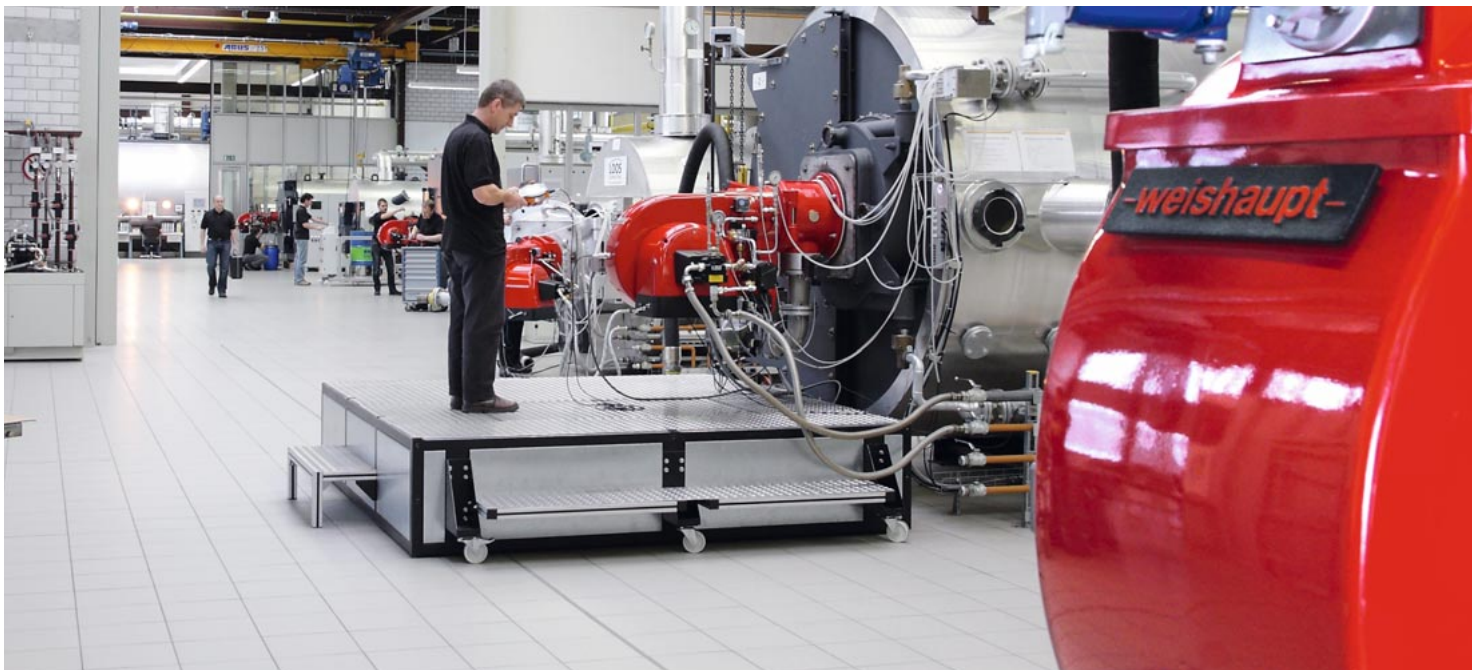

The burner technology of tomorrow is tested in the Research and Development Centre

Innovation comes from Weishaupt's in-house Research and Development Centre, whose new product developments have been setting benchmarks for decades. Burners and heating systems become ever cleaner, more economical, and easier to use.

At present, around 100 specialists in Schwendi are committed to fulfilling this task. They are an unrivalled team that combines special training, years of experience, craftsmanship, and creativity.

Skill and knowledge for Weishaupt's future-generating workshops also comes from test sites in the field and ongoing communication with our customers. The work is carried out using modern test equipment and design offices.

The latest production methods combine optimum working conditions and maximum conservation of resources. Our automated manufacturing centres, bright assembly halls and efficient work processes are all essential ingredients. Utmost reliability for our products is the goal.

A willingness to invest ensures a modern manufacturing facility and thus quality and efficiency. Burners for use around the world are manufactured at the main works in Schwendi.

Care, diligence and discipline shape our business. Every action and the smallest of parts is important, if the highest level of customer care is to be built into the burners and heating systems.

It is about the effectiveness of testing and control systems, the use of modern equipment, and the quality of materials, as well as logistics and organisation.

And it is decided by the human factor: "We deliver precision work," is the motto of every Weishaupt employee.



Burners for worldwide use are manufactured in a modern assembly hall



All marine burners are fully tested on special test rigs prior to delivery

If you
need
us,
we're
there.

Max Weishaupt SE

88475 Schwendi

Tel +49 7353 830

Fax +49 7353 83358

www.weishaupt.de

Print No. 83212602, January 2024

We reserve the right to make amendments.

Reprinting prohibited.

Some illustrations depict optional extras
that are available at additional cost.

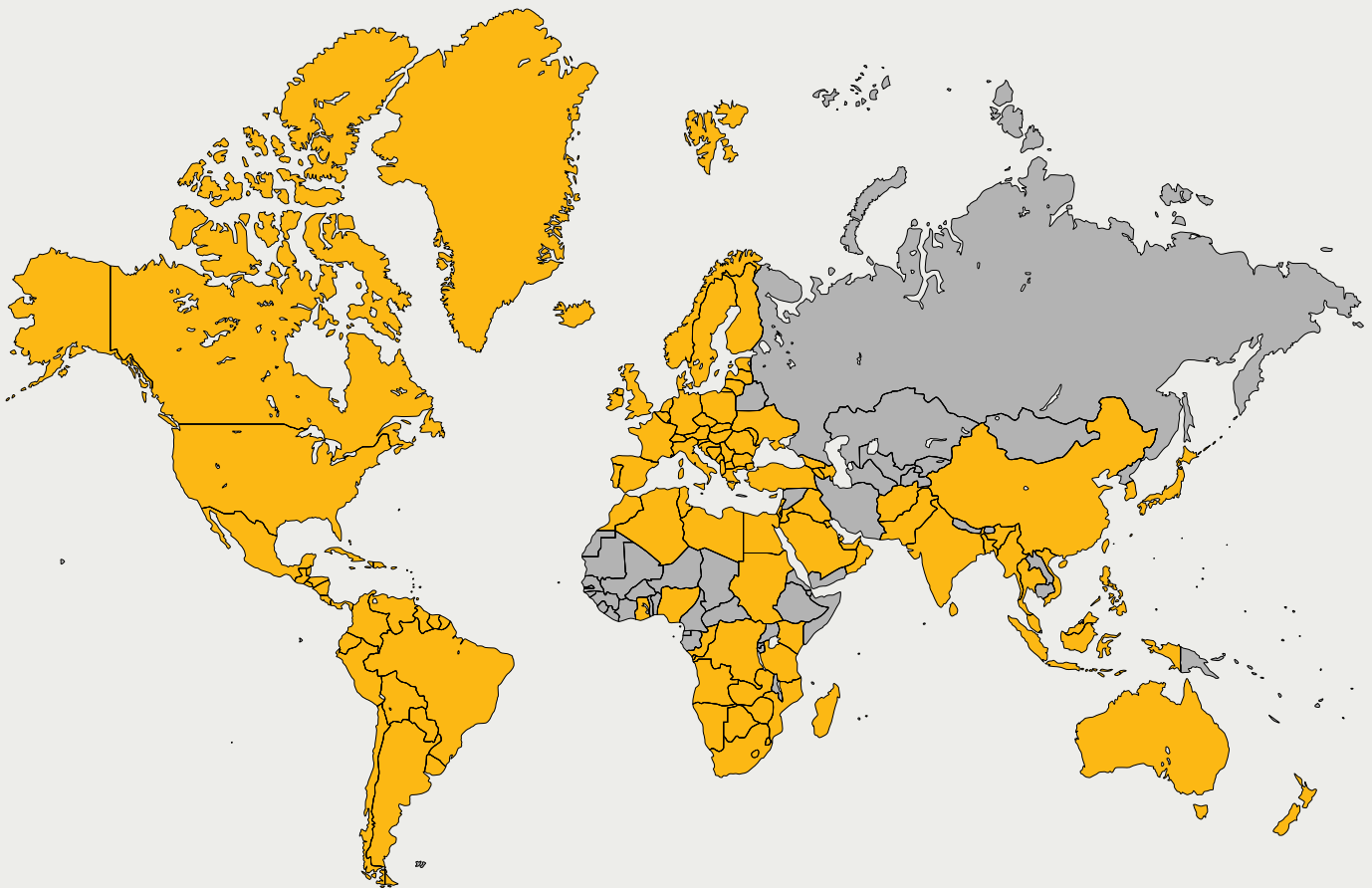

Weishaupt worldwide:

- | | | | | | | | |
|--------------------|-----------------|---------------|---------------|-----------------|--------------|----------------|--------------|
| Afghanistan | Chile | Faroe Islands | Israel | Malaysia | Oman | South Africa | Vatican City |
| Algeria | China | Finland | Italy | Malta | Pakistan | Spain | Venezuela |
| Angola | Columbia | France | Jamaica | Mauritius | Panama | Sri Lanka | Vietnam |
| Argentina | Congo (D. Rep.) | French Guiana | Japan | Mexico | Paraguay | Sudan | Zambia |
| Australia | Congo (Rep.) | Germany | Jordan | Moldova | Peru | Suriname | Zimbabwe |
| Austria | Costa Rica | Ghana | Kenya | Monaco | Philippines | Sweden | |
| Bahrain | Croatia | Greece | Korea (S.) | Montenegro | Poland | Switzerland | |
| Bangladesh | Cuba | Greenland | Kosovo | Morocco | Portugal | Taiwan | |
| Belgium | Cyprus | Guatemala | Kuwait | Mozambique | Puerto Rico | Tanzania | |
| Belize | Czechia | Guyana | Latvia | Myanmar | Qatar | Thailand | |
| Bolivia | Denmark | Haiti | Lebanon | Namibia | Romania | Tunisia | |
| Bosnia-Herzegovina | Dominican Rep. | Honduras | Lesotho | Netherlands | San Marino | Turkey | |
| Botswana | Ecuador | Hungary | Libya | New Zealand | Saudi Arabia | UAE | |
| Brazil | Egypt | India | Liechtenstein | Nicaragua | Serbia | Ukraine | |
| Bulgaria | El Salvador | Indonesia | Lithuania | Nigeria | Singapore | United Kingdom | |
| Canada | Estonia | Iraq | Luxembourg | North Macedonia | Slovakia | Uruguay | |
| | Eswatini | Ireland | Madagascar | Norway | Slovenia | USA | |